

Western-Cullen-Hayes Highway Crossing Bells

Western-Cullen-Hayes manufactures a wide range of electronic and mechanical warning bells for every type of highway crossing application. Loud and soft tone hammers are available for the mechanical bells; while the electronic bell's volume can be easily adjusted on its solid state circuit board. All bells have an adjustable ringing rate.

Our bells are constructed of light weight, rust-proof cast aluminum, and are designed to offer years of extremely low maintenance service. Western-Cullen-Hayes crossing bells offer unsurpassed sound quality and intensity.

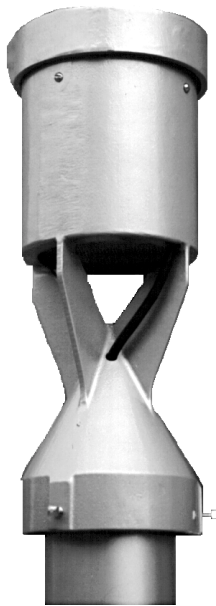

0777 Electronic Bell



0333/0666 Mechanical Bell

Dimensions:

Height: 18 inches
 Diameter: 6-1/2 inches
 Weight: 10 pounds
 Decibels: 80-95 db at 10 feet
 in a 360° plane

Dimensions:

Height: 15 inches
 Width: 14 inches
 Depth: 7 inches
 Weight: 27 pounds
 Decibels: 90 db at 10 feet

Ref.	Description	Part Number
A	Model 0333, 6 - 16 VDC, 600 mA For 4" and 5" top of mast mount For 6" top of mast mount For surface mount For side of mast mount. Specify 4" or 5"	0333 - CFR 0333 - HR 0333 - ARP 0333 - ARP - X
B	Model 0333-2, 6 - 16 VAC/VDC, 600 mA For 4" and 5" top of mast mount For 6" top of mast mount For surface mount For side of mast mount. Specify 4" or 5"	0333 - CFR - 2 0333 - HR - 2 0333 - ARP - 2 0333 - ARP - 2 - X
C	Model 0666, 105 - 125 VAC, 1.2 Amp. For 4" and 5" top of mast mount For 6" top of mast mount For surface mount For side of mast mount. Specify 4" or 5"	0666 - CFR 0666 - HR 0666 - ARP 0666 - ARP - X
D	Model 0777 electronic bell, 9-15VDC or AC,150 mA For 4" or 5" top of mast mount	0777-CFR
NOTE	For soft tone mechanical bell, add suffix -S	

WESTERN-CULLEN-HAYES, INC.2700 W. 36TH PLACE
(773) 254-9600CHICAGO, IL. 60632
FAX (773) 254-1110



This Page Left Blank Intentionally

Model 0777 Electronic Highway Crossing Bell

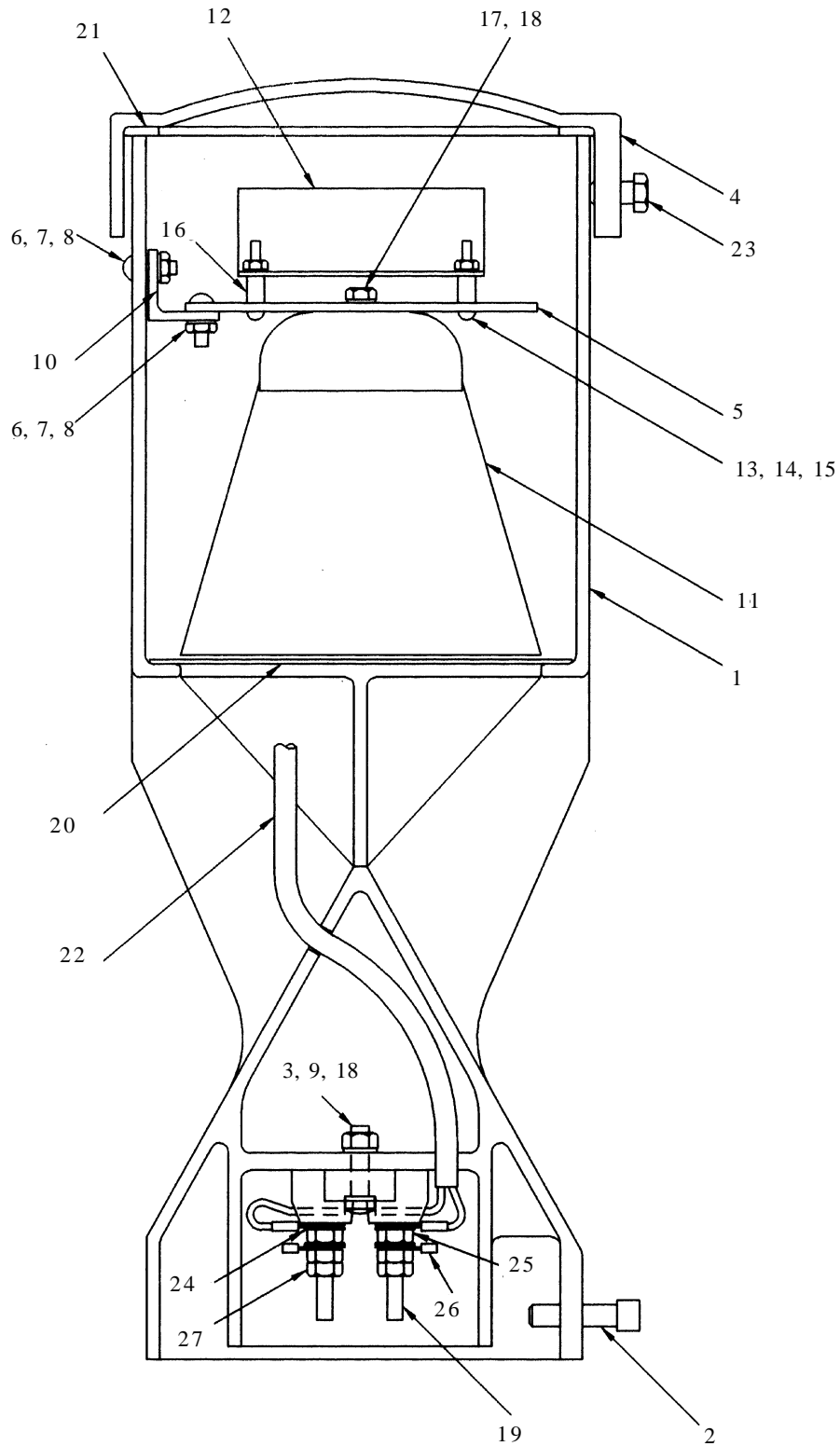

WESTERN-CULLEN-HAYES, INC.
2700 W. 36TH PLACE CHICAGO, IL. 60632
(773) 254-9600 FAX (773) 254-1110



Model 0777 Parts List

Reference	Description	Part No.
1	Electronic Bell Housing	1300
2	5/16"-18 x 1-1/4" Set Screw	DD-24-GG-3-0125
3	1/4"-20 x 1" Fillister Head Screw	BB-16-EE-3-01
4	Pinnacle	110-A-16
5	Speaker Mounting Plate	1300-5
6	10-32 x 5/8" Round Head Machine Screw	AA-10-DD-3-0062
7	#10 Lockwasher	RR-00-AH-3
8	#10-32 Hex Nut	JJ-12-DD-3
9	1/4"-20 Hex Nut	JJ-12-EE-3
10	Mounting Plate Support	1300-9
11	Speaker	1300-6
12	Bell Circuit Board	1300-8
13	6-32 x 1" Round Head Machine Screw	AA-10-AA-3-01
14	#6-32 Hex Nut	JJ-12-AA-3
15	#6 Lockwasher	RR-00-AF-3
16	Spacer	39-0054-1
17	M6 x 25MM Hex Head Bolt	1300-7
18	1/4" Lockwasher	RR-00-AJ-3
19	Terminal Strip	2507-2
20	Speaker Screen	1300-12
21	Pinnacle Gasket (20" long)	3590-258
22	Cable Assembly	1300-14
23	5/16"-18 x 5/8" Hex Head Bolt	BB-12-GG-3-0062
24	AAR Washer	10708
25	AAR Clamp Nut	10707
26	White Marking Tag	16222-W
27	Binding Nut	10706

WESTERN-CULLEN-HAYES, INC.

2700 W. 36TH PLACE CHICAGO, IL. 60632
(773) 254-9600 FAX (773) 254-1110

Model 0333 DC Highway Crossing Bell

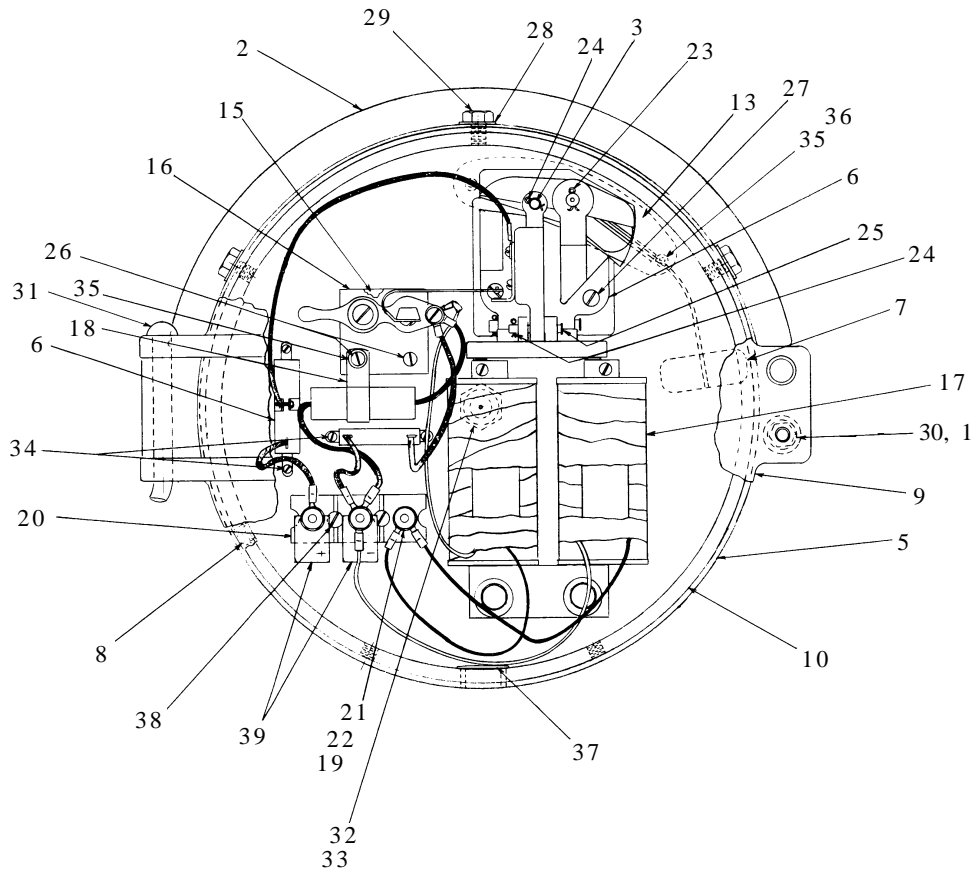

Ref.	Description	Part Number
1	Push Nut	970-45
2	Rain Shield	1208-CA
3	1/4" X 1-1/4" Clevis Pin	1209-16
5	Gong	1211
6	Movement Base Assembly	1215-B*
*	Movement Base Sub-Assembly	1209-1
*	Armature & Pins Sub-Assembly	1209-2
*	Operating Link	1209-4
*	1/4" x 2" Clevis Pin	1209-17
*	Contact Arm	1210-5
*	Resistor Sub-Assembly	1210-42

WESTERN-CULLEN-HAYES, INC.

2700 W. 36TH PLACE CHICAGO, IL. 60632
 (773) 254-9600 FAX (773) 254-1110

**Model 0333 DC Parts List - Continued**

Ref.	Description	Part Number
7	Oscillator & Hammer Assembly	1215-1**
**	Oscillator	1209-11
**	Hammer & Reinforcement Spring	1210-17
8	Cover Gasket	1217-2
9	Cover	1219-2-M
10	Case	1220-2-M
13	Dust Guard-Felt	1248-15-1
15	Contact Block Insulator	1249-16-1
16	Contact Block Assembly	1249-26-1
17	Coil & Core Assembly	1249-30
18	Cable Clamp	1953-30-1
19	Clamp Nut	10707
20	Terminal Strip	2508-69-3
21	Binding Nut	10706
22	Washer	10708
23	1/16" X 1/2" Cotter Pin	VV-00-AZ-3-005
24	1/16" X 3/8" Cotter Pin	VV-00-AZ-3-0037
25	3/16" X 1" Clevis Pin	1209-15
26	10-32 X 1" Filister Screw	AA-16-DD-3-01
27	1/4"-20 X 7/8" Filister Screw	AA-16-EE-3-0087
28	.328" Brass Washer	PP-00-AK-8
29	5/16"-18 X 3/4" Hex Bolt	BB-12-GG-3-0062
30	5/16"-18 X 1" Hex Bolt	BB-12-GG-3-01
31	3/8" X 3-1/2" Rivet	1249-40
32	1/2"-13 X 7/8" Hex Bolt	BB-12-PP-3-0087
33	1/2" Split Lockwasher	RR-00-AP-3
34	#6-32 X 1/4" Round Head Screw	AA-10-AA-3-0025
35	#10 Steel Washer	PP-00-AH-3
36	#10-32 X 1/4" Round Head Screw	AA-10-DD-3-0025
37	Wire Protective Bushing	1210-50
38	1/4"-20 X 3/4" Filister Screw	AA-16-EE-3-0075
39	White Marking Tag	16222-W

WESTERN-CULLEN-HAYES, INC.2700 W. 36TH PLACE CHICAGO, IL. 60632
(773) 254-9600 FAX (773) 254-1110

Model 0333-2 AC/DC Highway Crossing Bell

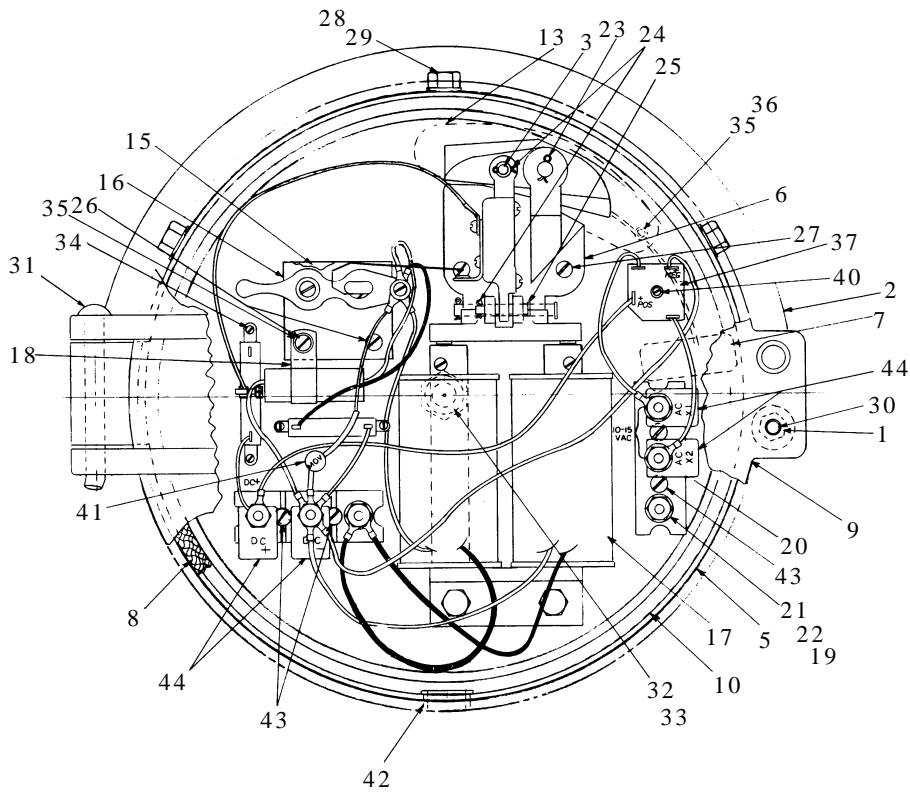

Ref.	Description	Part Number
1	Push Nut	970-45
2	Rain Shield	1208-CA
3	1/4" X 1-1/4" Clevis Pin	1209-16
5	Gong	1211
6	Movement Base Assembly	1215-B*
*	Movement Base Sub-Assembly	1209-1
*	Armature & Pins Sub-Assembly	1209-2
*	Operating Link	1209-4
*	1/4" x 2" Clevis Pin	1209-17
*	Contact Arm	1210-5
*	Resistor Sub-Assembly	1210-42

WESTERN-CULLEN-HAYES, INC.

2700 W. 36TH PLACE
(773) 254-9600

CHICAGO, IL. 60632
FAX (773) 254-1110

**Model 0333-2 AC/DC Parts List - Continued**

Ref.	Description	Part Number
7	Oscillator & Hammer Assembly	1215-1**
**	Oscillator	1209-11
**	Hammer & Reinforcement Spring	1210-17
8	Cover Gasket	1217-2
9	Cover	1219-2-M
10	Case	1220-2-M
13	Dust Guard-Felt	1248-15-1
15	Contact Block Insulator	1249-16-1
16	Contact Block Assembly	1249-26-1
17	Coil & Core Assembly	1249-30
18	Cable Clamp	1953-30-1
19	Clamp Nut	10707
20	Terminal Strip	2508-69-3
21	Binding Nut	10706
22	Washer	10708
23	1/16" X 1/2" Cotter Pin	VV-00-AZ-3-005
24	1/16" X 3/8" Cotter Pin	VV-00-AZ-3-0037
25	3/16" X 1" Clevis Pin	1209-15
26	10-32 X 1" Filister Screw	AA-16-DD-3-01
27	1/4"-20 X 7/8" Filister Screw	AA-16-EE-3-0087
28	.328" Brass Washer	PP-00-AK-8
29	5/16"-18 X 3/4" Hex Bolt	BB-12-GG-3-0062
30	5/16"-18 X 1" Hex Bolt	BB-12-GG-3-01
31	3/8" X 3-1/2" Rivet	1249-40
32	1/2"-13 X 7/8" Hex Screw	BB-12-PP-3-0087
33	1/2" Split Lockwasher	RR-00-AP-3
34	#6-32 X 1/4" Round Head Screw	AA-10-AA-3-0025
35	#10 Steel Washer	PP-00-AH-3
36	#10-32 X 1/4" Round Head Screw	AA-10-DD-3-0025
37	Rectifier Sub Assembly	1210-46-1
40	#8-32 X 3/4" Round Head Screw	AA-10-BB-3-0075
41	MOV Assembly	1210-47
42	Wire Protective Bushing	1210-50
43	1/4"-20 X 3/4" Filister Screw	AA-16-EE-3-0075
44	White Marking Tag	16222-W

WESTERN-CULLEN-HAYES, INC.2700 W. 36TH PLACE CHICAGO, IL. 60632
(773) 254-9600 FAX (773) 254-1110

Model 0666 115 VAC Warning Bell

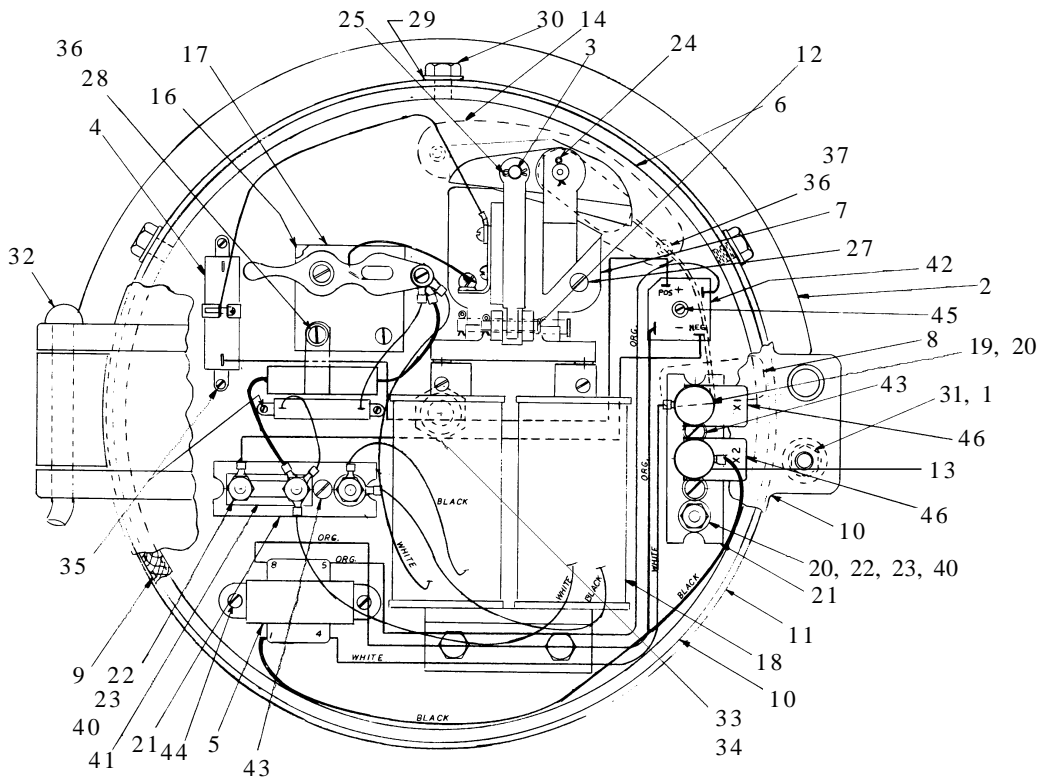

Ref.	Description	Part Number
1	Push Nut	970-45
2	Rain Shield	1208-CA
3	1/4" X 1 1/4" Clevis Pin	1209-16
4	Resistor Sub-Assembly	1210-42-1
5	Transformer Assembly 0666 Bell	37-1050-41-5
6	Gong	1211
7	Movement Base Sub-Assembly	1215-B*
*	Movement Base Sub-Assembly	1209-1
*	Armature & Pins Sub-Assembly	1209-2
*	Operating Link	1209-4
*	1/4" x 2" Clevis Pin	1209-17
*	Contact Arm	1210-5
8	Oscillator & Hammer Sub-Assembly	1215-1**
**	Oscillator	1209-11
**	Hammer & Reinforcement Spring	1210-17

WESTERN-CULLEN-HAYES, INC.

2700 W. 36TH PLACE
(773) 254-9600

CHICAGO, IL. 60632
FAX (773) 254-1110

**Model 0666 115 VAC Parts List - Continued**

Ref.	Description	Part Number
9	Packing Strip for Cover	1217-2
10	Bell Cover	1219-2-M
11	Case	1220-3
12	3/16" X 1" Clevis Pin	1209-15
13	Insulating Cap Black	R-2000-1
14	Dust Guard-Felt	1248-15-1
16	Contact Block Insulator	1249-16-1
17	Contact Block Sub-Assembly	1249-26-1
18	Coil & Core Assembly	1249-30
19	Insulating Cap Red	R-2000-1-R
20	Insulating Sleeve 1-1/2" Lg	R-2000-2-B
21	Terminal Strip	2508-69-3
22	Washer	10708
23	Binding Nut	10706
24	1/16" X 1/2" Cotter Pin	VV-00-AZ-3-005
25	1/16" X 3/8" Cotter Pin	VV-00-AZ-3-0037
27	1/4"-20 X 7/8" Filister Screw	AA-16-EE-3-0087
28	10-32 X 1" Filister Screw	AA-16-DD-3-01
29	.328" Brass Washer	PP-00-AK-8
30	5/16"-18 X 3/4" Hex Bolt	BB-12-GG-3-0062
31	5/16"-18 X 1" Hex Bolt	BB-12-GG-3-01
32	3/8" X 3-1/2" Rivet	1249-40
33	1/2"-13 X 7/8" Hex Screw	BB-12-PP-3-0087
34	1/2" Split Lockwasher	RR-00-AP-3
35	#6-32 X 1/4" Round Head Screw	AA-10-AA-3-0025
36	#10 Steel Washer	PP-00-AH-3
37	#10-32 X 1/4" Round Head Screw	AA-10-DD-3-0025
38	Cable Ties	MC-126-00027
39	#8-32 X 3/4" Round Head Screw	AA-10-BB-3-0075
40	Clamp Nut	10707
41	Shunting Plate	7323-2
42	Bridge Rectifier	1210-45
43	1/4-20 X 3/4" Filister Screw	AA-16-EE-3-0075
44	#8-32 X 1/4" Mach Screw	AA-10-BB-3-0025
45	#8-32 X 1/2" Mach Screw	AA-10-BB-3-005
46	White Marking Tag	16222-W

WESTERN-CULLEN-HAYES, INC.2700 W. 36TH PLACE CHICAGO, IL. 60632
(773) 254-9600 FAX (773) 254-1110

**Mounting Accessories
For CR Version**

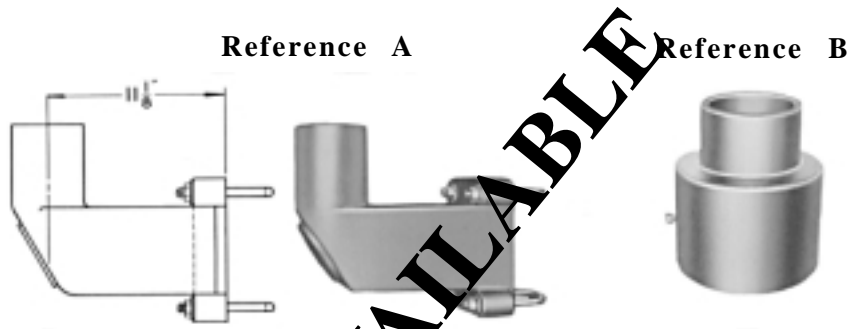

Special accessories are available for the mounting of the bell in a variety of locations.

Ref.	Description	Part Number
A	Gooseneck Bracket for mounting to: 3" ID pipe 3-1/2" ID pipe 4" ID pipe 5" ID pipe 6" ID pipe 8" ID pipe	873-27B 873-28B 873-29B 873-30B 873-31B 873-32B
B	Reducer 5" to 4" ID pipe	990-63
C	Bell Socket for 4" or 5" mast (Not Shown) Bell Socket for 6" mast (Not Shown)	1206-20 1206-6-CA

**Mounting Applications
For ARP Version**

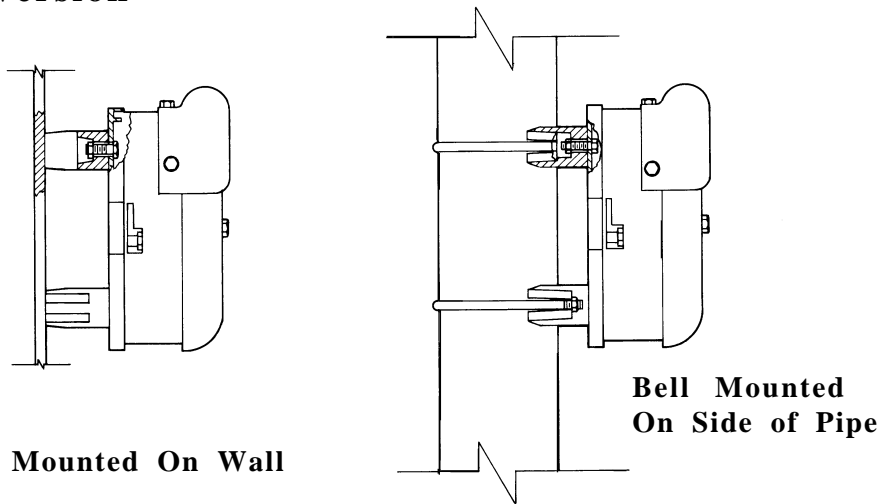

Type 555 Motor Driven Bell For Bulkhead Mounting or Top of Mast Mounting

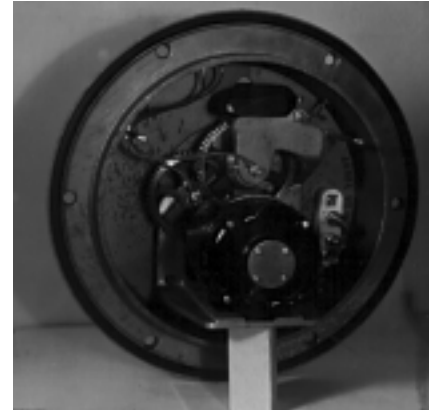

- **112 Strokes
Per Minute**
- **Twelve Inch Bell
Steel Gong**

- **Cast Aluminum
Housing**
- **With Exterior
Lubrication Points**

The Type 555 motor driven bell has an operating mechanism which consists of a motor, two gears and a bell hammer. Each hammer blow is distinct – so timed that the sound waves of the blow are not broken up by those of subsequent blows.

Operation. A cam, which is mounted on one of the gear wheels, engages and raises a weight to a certain point and then allows it to drop; this causes the bell hammer, which is connected to the operating weight by a shaft, to strike the gong, giving it a clear and penetrating sound.

Bulkhead Mount		Top of Mast Mount 4" - 5"	
Part Number	Voltage	Part Number	Voltage
0555-ACN-24-C	24 VDC	0555-C-12-11560	115 VAC
0555-ACN-37.5-C	37.5 VDC		
0555-ACN-74-C	74 VDC		
0555-ACN	115 VAC		

NOTE: 0555-ACN supplied without bell mechanism cover.

Type 555 Motor Driven Bell Parts List

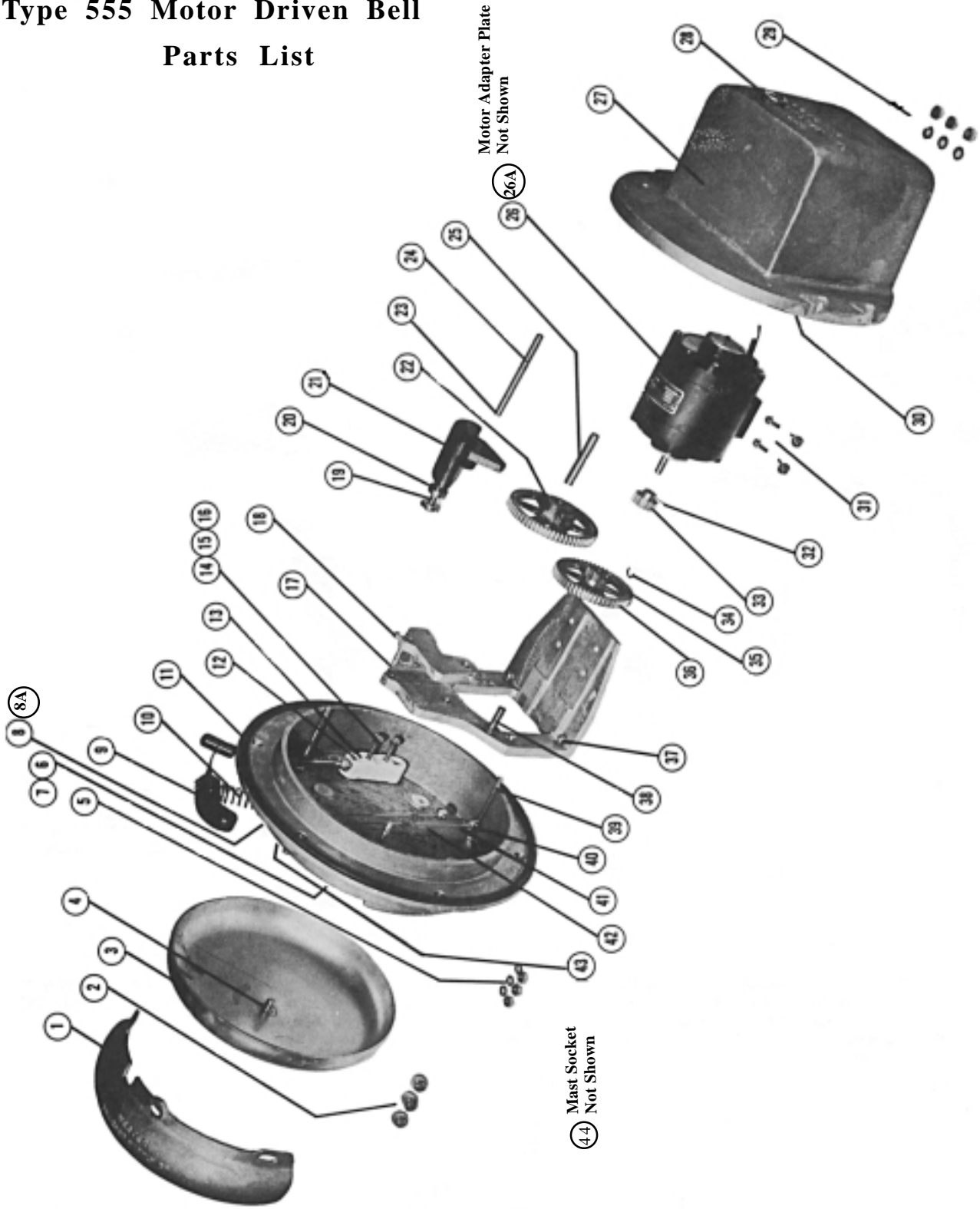



Type 555 Motor Driven Bell Parts List

Reference	Description	Part Number
1	Rainshield	1208-CA
2	5/16" - 18 x 5/8" Hex Bolt	BB-12-GG-3-0062
3	Gong	1211
4	1/2" - 13 x 7/8" Hex Bolt	BB-12-PP-3-0087
5 & 29	1/4" - 20 Hex Nut	JJ-12-EE-2
6	Spring Rocker	1508-6
7	#10 - 32 x 1-1/2" Round Head Screw	AA-10-DD-3-015
8	Bulkhead Mount Case	1506-EM
8A	Mast Mount Case	1506-CA
9	Hammer & Hammer Support	1508-55
10	Hammer Spring	1508-7
11	Gasket - 3/8" Dia. Neoprene Cord	MC-126-00002
12 & 37	1/4" - 20 x 7/8" Filister Screw	AA-16-EE-3-0087
13	Terminal Block	1056-18E
14	Binding Nut	10706
15	Clamp Nut	10707
16	Washer	10708
17	Gear Frame	1411-3-CA
18	10 - 32 x 1/2" Set Screw	DD-29-DD-3-005
19	Operating Weight Stud	1508-4
20	5/16" Plain Washer	PP-00-AK-3
21	Operating Weight	1508-45

**Type 555-ACN
Parts List - Continued**

Ref.	Description	Part Number
22	Drive Gear	1410-1
23	1/6" x 1/2" Cotter Pin	VV-00-AZ-3-005
24	Operating Weight Pin	1508-46
25	Drive Gear Shaft	1410-22
26	Motor Sub-Assy (Specify 24, 37.5, 74VDC, 115VAC)	
26A	Motor Adaptor Plate (Not Shown)	1411-12
27	Cover	1507-EM
28	1/2" Chase Nipple, Straight	RM-122-00001
30	Felt-Packing	1217-2
31	10/32" x 1-1/2" Round Head Screw	AA-10-DD-3-015
32	3/32" Dia. x 5/8" Roll Pin	WW-00-AY-3-0062
33	Pinion	1410-15-B
34	Snap Ring	254229
35	3/8" I.D. x 1-1/16" O.D. x 1/32" Washer	1410-32
36	Intermediate Gear & Pinion	1410-16
38	Intermediate Gear Stud	1508-141
39	Stud	1508-35
40	L-Fitting	15002-1
41	Hose Fitting	1508-47
42	Vinyl Tubing (Length as Req'd.)	3814-5
43	Oil Hole Cover	1508-44
44	Mast Socket for 4" or 5" Mast (Not Shown)	1206-20

WESTERN-CULLEN-HAYES, INC.

2700 W. 36TH PLACE
(773) 254-9600

CHICAGO, IL. 60632
FAX (773) 254-1110