



**Service and Installation
Manual for
Western-Cullen-Hayes, Inc.
Delectric Derail Operator**

9Part Number 401-00-01 with Power-Off Lock
Model C, 120 VAC Operation.
Beginning with Serial Number 1900

Orig. 7/1/94
Rev.U, 5-01-2016

WESTERN-CULLEN-HAYES, INC.
2700 West 36th Place, Chicago, IL 60632
Phone: 773-254-9600 Fax: 773-254-1110
Web Site: www.wch.com

THE DELECTRIC® DERAIL OPERATOR IS A MOTOR DRIVEN, REMOTELY CONTROLLED DEVICE FOR OPERATION OF WESTERN-CULLEN-HAYES MODEL HB SLIDING DERAILS AND CONNECTED ACCESSORIES.

THE DELECTRIC® DERAIL OPERATOR IS EQUIPPED WITH A POWER-OFF LOCKING FEATURE. WHEN POWER IS NOT PRESENT TO THE DELECTRIC®, THE LOCKING MECHANISM SOLENOID DEACTIVATES AND THE DERAIL CANNOT BE REMOVED FROM THE RAIL.

SHOULD IT BE NECESSARY TO OPERATE THE DERAIL WHEN POWER IS NOT PRESENT, THE COVER MUST BE UN-LOCKED AND OPENED TO DISENGAGE THE LOCK.

MANUAL OPERATION OF DERAIL IS ACCOMPLISHED BY PLACING THE RED EMERGENCY THROW LEVER INTO THE SOCKET OF THE OFFSET CRANK AND ROTATE THE CRANK TO THE DESIRED POSITION. CONTROL POWER IS INTERRUPTED WHEN THE HANDLE IS REMOVED. THIS OPERATION IS ALLOWED WHEN:

1. POWER IS PRESENT AT THE OPERATOR, THE HANDLE REMOVED, CONTROL INTERRUPTION INDICATOR LAMP IS LIT AND THE COVER IS CLOSED.
2. POWER IS NOT PRESENT, THE COVER IS OPEN AND THE HANDLE REMOVED.

A. CHECK TO BE CERTAIN THAT THE MATERIALS RECEIVED ARE CORRECT FOR YOUR APPLICATION:

1. DELECTRIC® DERAIL OPERATOR.
2. TYPE HB OR HBX DERAIL IN PROPER DIRECTION AND SIZE FOR YOUR APPLICATION.
3. FAR RAIL CONNECTING ROD PART NUMBER 404-00-01 OR NEAR RAIL CONNECTING ROD PART NUMBER 404-06-00.

B. ADDITIONAL MATERIALS CAN INCLUDE:

1. TARGET MOUNT WITH PROPER COLOR, TARGETS AND HARDWARE.
2. TARGET MOUNT, FAR RAIL CONNECTING ROD PART NUMBER 412-05-00 OR TARGET MOUNT, NEAR RAIL CONNECTING ROD PART NUMBER 412-08-00.
3. ELECTRIC SWITCH LAMP IN PROPER COLOR, ALUMINUM TYPE 1880-394 OR POLYCARBONATE TYPE PART NUMBER 38-0080-4.
4. SWITCH CIRCUIT CONTROLLER, TYPE 38-0100 WITH 2 OR 4 CONTACTS.
5. SWITCH CIRCUIT CONTROLLER, FAR RAIL CONNECTING ROD PART NUMBER 38-0100-200 OR SWITCH CIRCUIT CONTROLLER, NEAR RAIL CONNECTING ROD PART NUMBER 38-0100-201.
6. TERMINAL HOUSING FOR INSTALLATION WITHOUT SWITCH CIRCUIT CONTROLLER PART NUMBER 1182-26 OR FOR INSTALLATION WITH SWITCH CIRCUIT CONTROLLER PART NUMBER 1182-27.
7. ANY SPECIAL MATERIALS FOR YOUR APPLICATION.
8. ANY SPECIAL CONTROLS FOR YOUR APPLICATION.

FOR RIGHT ANGLE INSTALLATION, MATERIALS WILL INCLUDE:

9. RIGHT ANGLE CRANK PART NUMBER 410-00-00.
10. DELECTRIC® TO CRANK CONNECTING ROD PART NUMBER 407-03-00.
11. CRANK TO FAR RAIL DERAIL CONNECTING ROD PART NUMBER 406-00-00.
12. TWO OFFSET TUBES PART NUMBER 400-64-00.

C. PREINSTALLATION CHECKS:

1. MAKE CERTAIN THAT ALL TIES ARE IN SOUND CONDITION AND ARE THE PROPER 13'-6" LENGTH. WHEN INSTALLATION CALLS FOR RIGHT ANGLE APPLICATION, PREPARE THE TIES ACCORDINGLY.
2. CLEAR BALLAST FROM THE CONNECTING ROD AREA BETWEEN THE TIES.
3. CROP THE TIE PLATES FLUSH WITH THE EDGE OF THE RAIL BASE.
4. MAKE CERTAIN THAT A FUSE SAFETY DISCONNECT SWITCH SIZED FOR THE POWER SERVICE HAS BEEN PROVIDED.
5. MAKE CERTAIN THAT THE TERMINAL HOUSING IS PROPERLY INSTALLED SO ONLY THE TERMINAL BOX ITSELF IS ABOVE GROUND AND THE CONDUCTORS THAT HAVE BEEN RUN TO THE TERMINAL HOUSING FROM THE CONTROL LOCATION ARE:
 - a. 115 VAC, 30 AMP POWER SERVICE:
 1. #8 AWG MIN, FOR RUNS OF 0 TO 300 FEET
 2. #6 AWG MIN. FOR RUNS OF 300 TO 600 FEET
 3. #4 AWG MIN. FOR RUNS OF 600 TO 1000 FEET
 4. CALCULATE VOLTAGE DROP AND SIZE WIRE ACCORDINGLY FOR RUNS IN EXCESS OF 1000 FEET
 - b. CONTROL WIRING AND POSITION READ BACK CIRCUITS FROM THE DELECTRIC® DERAIL OPERATOR OR A SWITCH CIRCUIT CONTROLLER:
 1. #12 AWG MIN. FOR RUNS OF 0 TO 300 FEET
 2. #10 AWG MIN. FOR RUNS OF 300 TO 600 FEET
 3. #8 AWG MIN. FOR RUNS OF 600 TO 1000 FEET
 4. CALCULATE VOLTAGE DROP AND WIRE SIZE ACCORDINGLY FOR RUNS IN EXCESS OF 1000 FEET

D. DERAIl INSTALLATION:

THE DERAIl MUST BE PROPERLY INSTALLED FOR SAFE, EFFECTIVE OPERATION. REFER TO THE WESTERN-CULLEN-HAYES DERAIl INSTALLATION, INSPECTION AND MAINTENANCE BOOKLET INCLUDED SEPARATELY, AS WELL AS INSTRUCTIONS PACKAGED WITH THE DERAIl.

THE FOLLOWING INSTRUCTIONS ARE ESPECIALLY IMPORTANT:

1. MEASURE THE VERTICAL DISTANCE FROM THE TOP OF THE TIE TO THE TOP OF THE RAIL ON WHICH THE DERAIl WILL BE SECURED. BE SURE TO INCLUDE THE THICKNESS OF THE CROPPED TIE PLATE IN THIS MEASUREMENT. THIS DISTANCE MUST BE IN EVEN INCHES AND MATCH THE DERAIl SIZE AS STAMPED ON THE DERAIl NAMEPLATE. IF THE RAIL HEIGHT IS NOT THE SAME AS THE DERAIl SIZE, ADJUSTMENT FOR HEIGHT MAY BE MADE BY PLACING STEEL PLATES UNDER THE DERAIl TO RAISE THE DERAIl, OR BY ADZING THE TIE DIRECTLY UNDER THE DERAIl TO LOWER THE DERAIl. THE LIMIT OF THIS ADJUSTMENT SHALL BE NO MORE THAN 1/2" IN EITHER DIRECTION.

FAILURE TO OBSERVE THIS FUNDAMENTAL REQUIREMENT WILL RESULT IN THE INABILITY OF THE DERAIl BLOCK TO SEAT PROPERLY ON THE HEAD OF THE RAIL. THIS CONDITION COULD RESULT IN A NON-DERAIlMENT OR MAY CAUSE DAMAGE TO THE DERAIl OR DERAIl OPERATOR DURING A DERAIlMENT.

2. BE CERTAIN THAT THE DERAIl BOX TABS FIT SNUGLY AGAINST THE WEB OF THE RAIL. IF HEIGHT INSTALLATION INSTRUCTIONS WERE CAREFULLY FOLLOWED, AND THE DERAIl IS SNUG AGAINST THE RAIL, THE DERAIlING SURFACE WILL SIT FLAT AND COVER THE HEAD OF THE RAIL, AND WILL OVERHANG THE OUTSIDE HEAD OF THE RAIL BY APX. 1/2".
3. BE CERTAIN THAT THE DERAIl IS SECURED TO THE MOUNTING SURFACE. INSTALL A LAG SCREW, SPIKE OR BOLT IN EACH MOUNTING HOLE. 15/16" X 6" LAG BOLTS ARE THE PREFERRED METHOD OF SECUREMENT.
4. WHEN CONNECTING A DELECTRIC® DERAIl OPERATOR TO AN EXISTING DERAIl, BE CERTAIN THAT THE PRECEDING REQUIREMENTS ARE TRUE AND THAT THE DERAIl IS IN GOOD OPERATIONAL CONDITION.

E. DELECTRIC® INSTALLATION:

FOR THIS EXAMPLE, REFER TO DRAWING DSL-1005 FOR FAR RAIL INSTALLATION:

1. SET THE DELECTRIC® IN POSITION, BUT DO NOT SECURE AT THIS TIME.
2. PLACE THE DERAIL IN THE OFF-RAIL POSITION. THE DELECTRIC® IS SHIPPED WITH THE RAM RETRACTED. THIS IS ALSO THE OFF-RAIL POSITION.
3. INSTALL THE OFFSET CONNECTING ROD. THE END OF THE ROD WITH THE 7/8" X 1" MACHINED LUG CONNECTS TO THE DELECTRIC® . CONNECT THE ROD SO THAT THE MACHINED LUG FACES UPWARD. REFERRING TO FIGURE 1 BELOW, POSITION THE MACHINED LUG INTO THE HOLE IN THE OFFSET LINK ASSEMBLY AS SHOWN.

DELECTRIC® RAM AND OFFSET LINK RETRACTED.

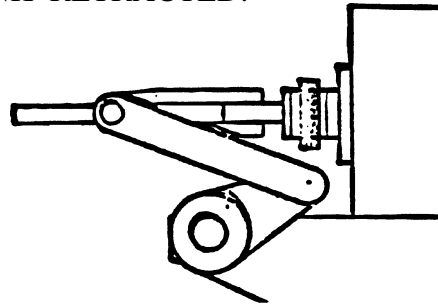

THIS VIEW SHOWS THE DELECTRIC® RAM IN THE RETRACTED POSITION AND THE PROPER ALIGNMENT OF THE OFFSET LINK. THE DERAIL IS OFF-RAIL IN THIS POSITION.

DELECTRIC® RAM AND OFFSET LINK EXTENDED.

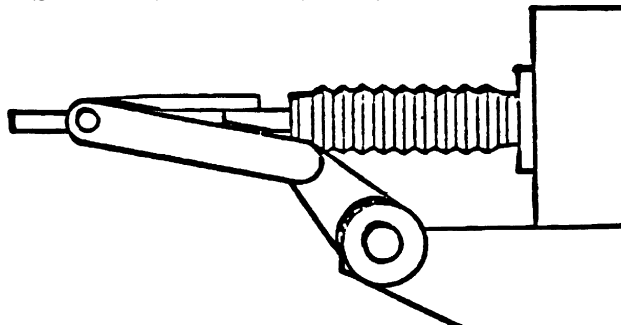

THIS VIEW SHOWS THE DELECTRIC® RAM IN THE EXTENDED POSITION AND THE PROPER ALIGNMENT OF THE OFFSET LINK. THE DERAIL IS IN THE ON-RAIL IN THIS POSITION.

THE OFFSET LINK MUST BE IN THESE POSITIONS TO PREVENT THE MECHANISM FROM BINDING AND POSSIBLY CAUSING DAMAGE TO THE DELECTRIC® OPERATOR.

4. CONNECT THE OTHER END OF THE ROD TO THE DERAIL LUG THAT ALLOWS THE ROD TO RUN MOST PARALLEL TO THE TIES. DO NOT INSTALL COTTER PIN AT THIS TIME.
5. POSITION THE DERAIL® OPERATOR SO THE ROD IS PARALLEL TO THE TIES AND THE OPERATOR AND ROD ARE AT RIGHT ANGLES TO THE RAIL.
6. SECURELY FASTEN THE DELECTRIC® TO THE TIES USING ALL AVAILABLE MOUNTING HOLES.

F. ADJUSTING THE STROKE:

NOTE: DO NOT ATTEMPT TO OPERATE THE DELECTRIC® DERAIL OPERATOR WITH THE RED EMERGENCY THROW LEVER UNLESS THE COVER IS OPEN AND THE POWER-OFF LOCK IS DE-ACTIVATED.

1. WITH THE COVER OPEN, USE THE RED EMERGENCY THROW LEVER TO OPERATE THE DERAIL ON THE OFF RAIL SEVERAL TIMES.
2. CHECK THE BUFFER SPRINGS FOR LACK OF COMPRESSION AFTER EACH MOVEMENT BY SPINNING THE SPRINGS. THE SPRINGS ARE LOCATED AT THE REAR MOTOR MOUNTING.
3. IF SPRING COMPRESSION IS NOTED, THEN CONNECTING ROD ADJUSTMENT IS REQUIRED. DISCONNECT THE CONNECTING ROD AT THE DERAIL END AND ADJUST THE SCREW JAW IN OR OUT AS REQUIRED. IF COMPRESSION IS NOTED IN THE SPRINGS TO THE REAR OF THE DELECTRIC® CASE, ADJUST THE SCREW JAW TO SHORTEN THE ROD. IF COMPRESSION IS NOTED IN THE SPRINGS TO THE FRONT OF THE CASE, ADJUST THE SCREW JAW TO LENGTHEN THE ROD. IF ADEQUATE ADJUSTMENT CANNOT BE ACHIEVED, REPEAT PROCEDURE AT THE SCREW JAW LOCATED AT THE DELECTRIC® END OF THE ROD.

WHEN PROPERLY ADJUSTED, SPRINGS MAY BE SLIGHTLY COMPRESSED AND SHOULD BE ABLE TO BE ROTATED WITH A MINIMUM AMOUNT OF FORCE.

4. RECONNECT THE ROD AND RETEST FOR SPRING COMPRESSION. TIGHTEN SCREW JAW LOCK NUTS AND INSTALL ALL COTTER PINS AND SPREAD.
5. CONNECT THE SEALTITE FITTING AND SEALTITE TO THE TERMINAL HOUSING 1182-26 OR 1182-27, IF USED.

G. ELECTRICAL CONNECTIONS:

REFER TO ELECTRICAL DIAGRAM 401-01-00:

1. CONNECT 115 VAC, 30 AMP SERVICE AND GROUND TO TERMINALS X1, X2 AND G.,
2. CONNECT CONTROLLING DEVICE AS FOLLOWS:
 - a. COMMON OR HEAL TO TERMINAL 4.
 - b. EXTEND, OR ON-RAIL IF FAR RAIL APPLICATION, TO TERMINAL 5.
 - c. RETRACT, OR OFF-RAIL IF FAR RAIL APPLICATION, TO TERMINAL 9.
 - d. IF A TRACK CIRCUIT IS INSTALLED, BREAK WIRE 4 WITH THE TR CONTACTS.
 - e. IF USING A NEAR RAIL APPLICATION, REVERSE CONTROL WIRES 5 & 9.
3. CONNECT READ BACK AS FOLLOWS:
 - a. EXTEND READ BACK TO TERMINALS 12 & 13.
 - b. RETRACT READ BACK TO TERMINALS 14 & 15.
4. APPLY POWER TO THE UNIT AND OPERATE SEVERAL TIMES. OBSERVE THE DERAIL TRAVEL AND THE CONNECTING RODS FOR FREE MOVEMENT.
5. FINALIZE ALL CONNECTIONS AND BE CERTAIN THAT ALL WIRES ARE FREE FROM MOVING PARTS.
6. CHECK ALL PHASES OF THE INSTALLATION AGAINST THE CHECK LIST.
7. CLOSE COVER AND SECURE COVER NUT. **THE COVER MUST BE SECURED TO INSURE PROPER OPERATION OF THE POWER-OFF LOCK MECHANISM.** REPLACE EMERGENCY THROW LEVER INTO IT'S SOCKET. PADLOCK COVER AND HANDLE.
8. WHEN ALL EQUIPMENT IS INSTALLED, REFILL THE SPACE BETWEEN THE TIES WITH BALLAST UP TO APPROXIMATELY 2" BELOW THE CONNECTING RODS WHEN THE DERAIL IS OFF-RAIL.

H. ACCESSORY INSTALLATION:

TARGET MOUNT:

1. CONNECT THE TARGET MOUNT CONNECTING ROD TO THE DERAIL LUG WHICH WILL ALLOW THE ROD TO BE MOST PARALLEL WITH THE TIES.
INSTALL COTTER PIN AND SPREAD.
2. INSTALL THE TARGETS TO THE MOUNT.
3. WITH THE DERAIL IN THE ON-RAIL POSITION, POSITION THE TARGET MOUNT SO THE TARGETS COLORS THAT PRESENT RESTRICTIVE MOVEMENT ARE DISPLAYED PARALLEL TO THE TRACKS. ADJUST THE TARGET MOUNT EYE BOLT UNTIL THE END OF THE CONNECTING ROD FITS EASILY INTO THE EYE BOLT WHEN THE EYE BOLT IS AT THE FAR END OF ITS TRAVEL. CHECK FINAL TARGET POSITIONING AND SECURE THE TARGET MOUNT TO THE TIES USING ALL AVAILABLE MOUNTING HOLES. OPERATE THE DERAIL AND BE CERTAIN THAT THE TARGETS ROTATE TO THE PROPER POSITION AND THAT THE CONNECTING ROD DOES NOT BIND IN THE EYE BOLT OR RUB AGAINST THE TIES OR THE DERAIL OPERATOR.

SWITCH CIRCUIT CONTROLLER:

1. PLACE THE DERAIL ON-RAIL. INSTALL THE SCREW JAW END OF THE CONTROLLER CONNECTING ROD TO THE LEFT LUG ON THE DERAIL, AS VIEWED FROM THE REAR OF THE DERAIL.
2. PLACE THE CONTROLLER ON THE LEFT TIE, APPROXIMATELY 20" FROM THE CENTER OF THE CONTROLLER SHAFT TO GAUGE.
3. WITHOUT MOVING THE CONTROLLER, ROTATE THE CONTROLLER SHAFT CRANK TOWARD THE RAIL AND LOOSELY CONNECT THE CONNECTING ROD TO THE SHAFT CRANK ARM BALL STUD.
4. ALIGN THE CONTROLLER ON THE TIE SO THE CONNECTING ROD IS MOSTLY PARALLEL TO THE TIES.
5. SECURE THE CONTROLLER TO THE TIES USING THE FOUR CORNER MOUNTING HOLES.

6. TIGHTEN THE CONNECTING ROD BALL SOCKET AND INSTALL COTTER PIN IN DERAIL END OF THE CONNECTING ROD AND SPREAD.
7. INSTALL THE SEALTITE FITTINGS AND SEALTITE FROM THE CONTROLLER TO THE TERMINAL HOUSING, 1182-27, IF USED.
8. ADJUST THE CONTROLLER CAMS FOR DESIRED CONTACT OPERATION.
9. REFER TO CATALOG SECTION 16, MODEL 100 CIRCUIT CONTROLLERS FOR FURTHER INFORMATION.

INSTRUCTIONS FOR ADDITIONAL DERAIL STATION EQUIPMENT SUCH AS AN AUTO-MECHANICAL BLUE FLAG OR DERAIL WHEEL CROWDER, ARE INCLUDED WITH THIS EQUIPMENT.

WHEN ALL EQUIPMENT IS INSTALLED, REFILL THE SPACE BETWEEN THE TIES WITH BALLAST UP TO APPROXIMATELY 2" BELOW THE CONNECTING RODS WHEN THE DERAIL IS OFF-RAIL.

FINAL DELECTRIC® DERAIL STATION CHECKLIST.

1. _____ DERAIL FITS SNUG AGAINST THE WEB OF THE RAIL, DERAILING SHOE SITS FLAT ON TOP THE BALL OF THE RAIL AND OVERHANGS APX. 1/2". DERAIL IS LUBRICATED AND OPERATES FREELY.
2. _____ CONNECTING RODS ARE PARALLEL TO THE TIES AND DO NOT BIND. COTTER PINS ARE INSTALLED AND SCREW JAW LOCKNUTS ARE TIGHTENED.
3. _____ THERE IS NO COMPRESSION OF THE BUFFER SPRINGS WHEN THE MOTOR IS AT REST.
4. _____ ALL DEVICES ARE SECURED TO THE TRACKS USING ALL AVAILABLE MOUNTING SPACES.
5. _____ ALL TERMINATIONS ARE TIGHT, ALL WIRES ARE ROUTED AWAY FROM MOVING PARTS AND ALL WIRE ENTRANCES ARE SEALED, TERMINAL HOUSING TUBE IS SEALED AND COVER IS SECURED.
6. _____ ALL COVERS ARE SECURELY TIGHTENED AND PADLOCKS INSTALLED WHERE REQUIRED.
7. _____ TEST THE OPERATION OF THE POWER OFF LOCK:
 - a. POWER THE DERAIL ON-RAIL.
 - b. REMOVE INCOMING POWER SERVICE.
 - c. INSERT EMERGENCY THROW LEVER INTO THE OFFSET LINK SOCKET AND ATTEMPT TO MOVE THE DERAIL.
THE DERAIL SHOULD NOT MOVE.
 - d. REINSERT HANDLE IN HOLDER, RESTORE POWER SERVICE AND POWER THE DERAIL OFF-RAIL.
REPEAT STEPS b & c.
 - e. RESTORE POWER AND RETURN EMERGENCY THROW HANDLE TO IT'S SOCKET AND SECURE WITH PADLOCK.

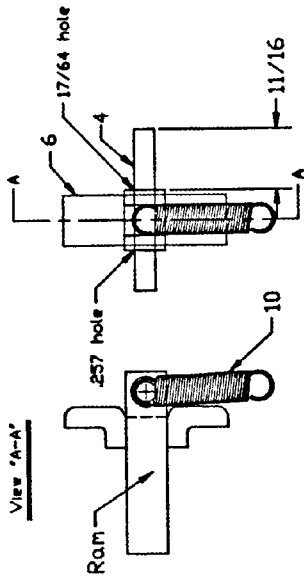

Note: slip roll pin through 17/64 hole and spring loop before tapping into place through .257 hole.
 Reinsert pin into Solenoid 401-60-04
 When assembling place long end (11/16) of the Roll pin (4) into the slot in the Pawl (3)

DETAIL A

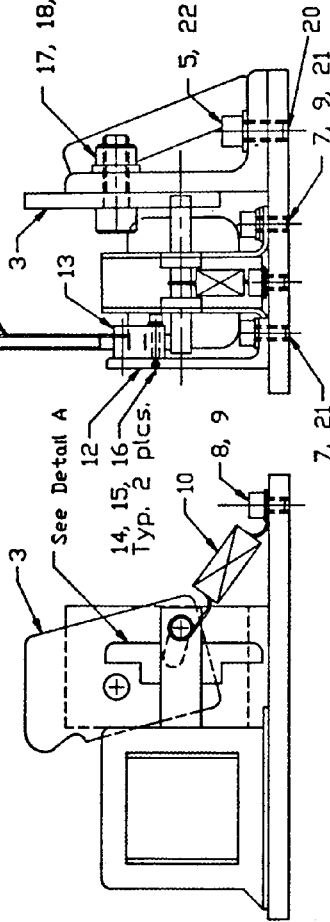
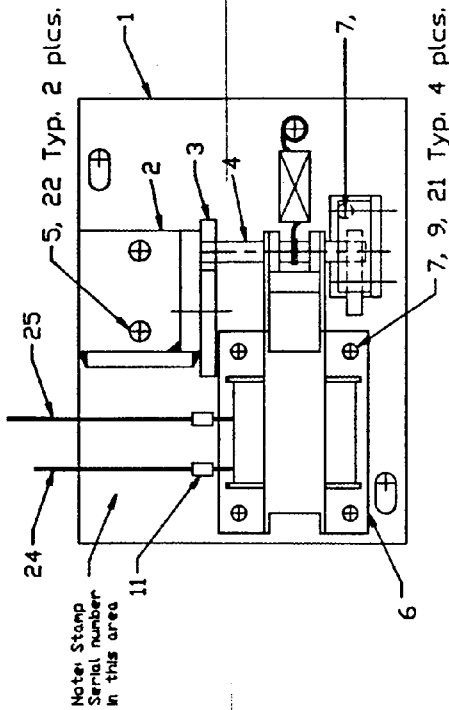

WESTERN-CULLEN-HAYES, Inc.		DATE	2/16/74
Delectric Lock Assy		DATE	
THIS DRAWING IS THE PROPERTY OF WESTERN-CULLEN-HAYES, Inc. AND SHALL NOT BE REPRODUCED, COPIED OR USED IN ANY MANNER CONTRADICTORY TO THEIR INTERESTS.		DATE	
REV	BY	DATE	
C			
Full		DATE	
401-60-00		DATE	
REVISIONS		DATE	
USED ON		DATE	
1. UNLESS OTHERWISE SPECIFIED DIMENSIONS ARE IN INCHES			
TOLERANCE OR DECIMALS FRACTIONS			
.001 .010 .015 .030 .060 .125 .250 .500 .750 1.000			
FRACTIONS			
1/16 1/8 3/16 1/4 3/8 1/2 5/8 3/4 7/8 1 1 1/4 1 1/2 1 3/4 2 2 1/4 2 1/2 3 3 1/2 4 4 1/2 5 5 1/2 6 6 1/2 7 7 1/2 8 8 1/2 9 9 1/2 10 11 12 14 16 18 20 24 30 36 48 60 72 96 120 144 180 240 300 360 480 600 720 960 1200			

**401-60-00 DeLectric Lock Assy
Parts List**

Item	Part No.	Description	Quantity
1	401-60-10	BASE PLATE	1
2	401-60-02	PAWL RISER-MACH.	1
3	401-60-01	PAWL	1
4	WW-00-AJ-3-02	1/4" DIA x 2" ROLL PIN	1
5	BB-15-EE-3-005	1/4-20 x 1/2 LG SOCKET HD CAP SCREW	2
6	401-60-04	SOLENOID	1
7	BB-15-DD-3-0037	10-32 x 3/8 SOCKET HD CAP SCREW	6
8	BB-15-DD-3-0025	10-32 x 1/4 RD HD CAP SCREW	1
9	PP-00-AH-3	#10 PLATE STEEL WASHER	5
10	401-60-06	EXTENSION SPRING	1
11	RM-123-00001	1/4 SHRINK TUBE	2"
12	401-60-08	SWITCH RISER	1
13	401-60-07	MICRO-SWITCH	1
14	BB-10-BH-3-0062	#4-40 x 5/8 ROUND HEAD SCREW	2
15	PP-00-BD-3	#4 PLAIN STEEL WASHER	2
16	RR-00-BD-3	#4 SPLIT LOCKWASHER	2
17	BB-15-GG-3-01	5/16-18 x 1" SOCKET HD CAP SCREW	1
18	RR-00-AK-3	5/16 SPLIT LOCKWASHER	1
19	JJ-12-GG-3	5/16-18 HEX NUT	1
20	RR-00-AH-3	#10 SPLIT LOCKWASHER	6
21	RR-00-AJ-3	1/4 SPLIT LOCKWASHER	2
22	38-0045-95-W	16 GA TINNED COPPER WIRE WHITE	56"
23	38-0045-95	16 GA TIN COPPER WIRE	96"
24	50-0621	.187 x .020 SPADE TERMINAL	2
25	31885	TERMINAL	1

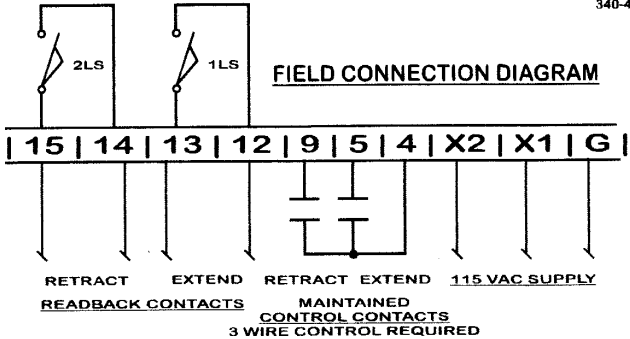
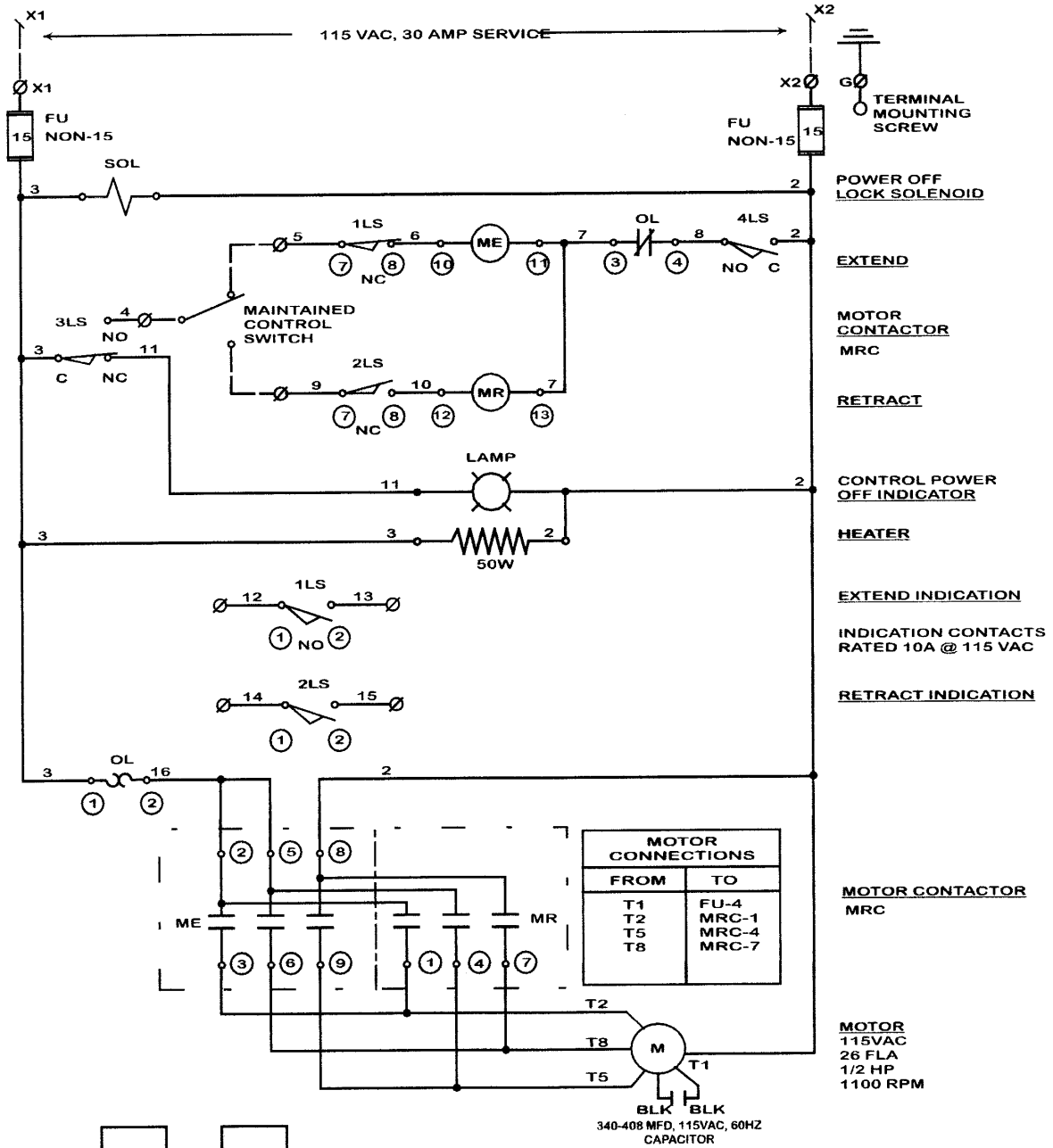

**DELECTRIC DERAIL OPERATOR
WIRING HARNESS AND
CONTROL WIRING DIAGRAM. 401-01-00.
REV. I**

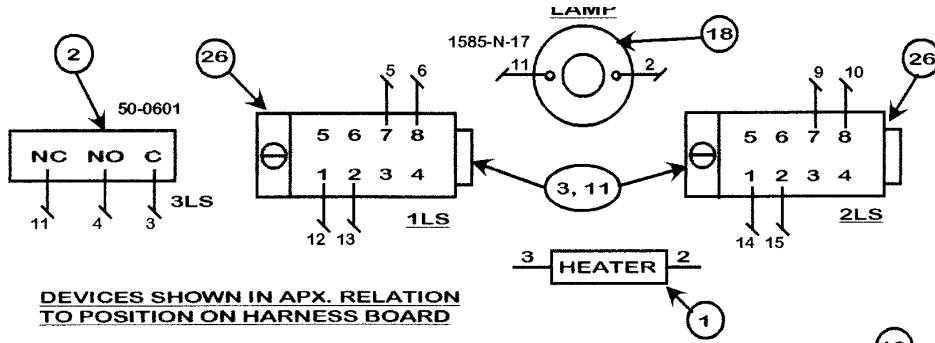

DEVICES SHOWN IN APX. RELATION TO POSITION ON HARNESS BOARD

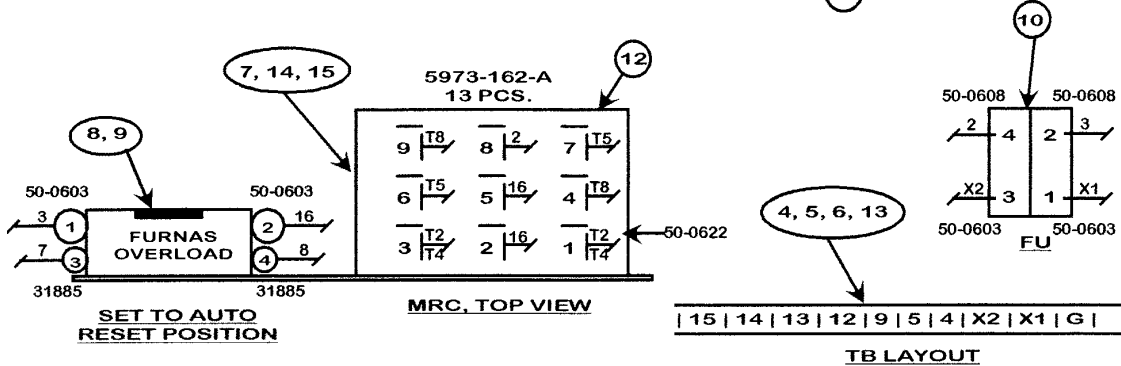

MRC, BOTTOM VIEW

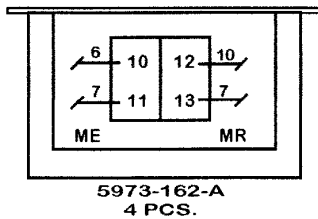

5973-162-A
4 PCS.

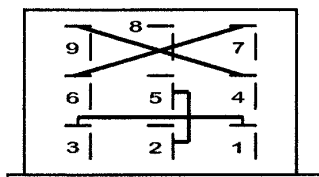

MRC, WIRE JUMPER DETAIL
1 TO 3, 2 TO 5, 4 TO 9, 6 TO 7

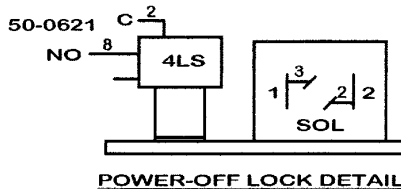

POWER-OFF LOCK DETAIL

POWER OFF LOCK CONNECTIONS		
WIRE NUMBER	FROM	TO
2	FU-4	SOL-2
2	SOL-2	4LS-C
8	4LS-NO	OL-4
3	OL-1	SOL-1

401-01-00 WIRE HARNESS RUNNING LIST		
WIRE NUMBER	FROM	TO
G	TB-G	TB SCREW
X1	TB-X1	FU-1
X2	TB-X2	FU-3
2	HEATER-2	LAMP-L2
2	LAMP-L2	FU-4
3	3LS-C	FU-2
3	FU-2	OL-1
3	3LS-C	HEATER-1
4	3LS-NO	TB-4
5	1LS-7	TB-5
6	1LS-8	MRC-10
7	MRC-11	OL-3
7	OL-3	MRC-13
9	2LS-7	TB-9
10	MRC-12	2LS-8
11	3LS-NC	LAMP-L1
12	1LS-1	TB-12
13	TB-13	1LS-2
14	2LS-1	TB-14
15	TB-15	2LS-2
16	OL-2	MRC-5

LIMIT SWITCH FUNCTION LIST	
1LS	RAM EXTENDED
2LS	RAM RETRACTED
3LS	EMG. THROW HANDLE REMOVED
4LS	POWER-OFF LOCK DE-ENERGIZED

Sliding Derails - Models HB and HBXS

The Model HB is comprised of two welded assemblies mated to become a derailing unit. The derail functions by the block having a shoe with a deflector bar that covers the running rail. These parts cover the head of the rail and they lift the wheel and flange over the rail head allowing the wheel to drop to the field side of the rail and retard forward movement. The guide box which is fixed to the ties on the gauge side of the rail, directs the movement of the derailing block on and off the rail.

Symbols:

All HB's have three connection lugs for operating or monitoring accessories. Model HBXS is a bi-directional derail for use in special locations where one-way derails cannot be utilized. The former Model HBP features have been incorporated into the Model HB.

Size:

The size number follows the model designation on the name plate on the derail guide box. This number indicates the distance in even inches from the top of the rail to the surface on which the derail guide box must be placed.

Derail Size	For Rail (and Tie Plate) Measuring
4	3-1/2 to 4-1/2 inches high
5	4-1/2 to 5-1/2 inches high
6	5-1/2 to 6-1/2 inches high
7	6-1/2 to 7-1/2 inches high
8	7-1/2 to 8-1/2 inches high

Positioning the derail:

It is very important that the derail be placed properly in respect to the rail.

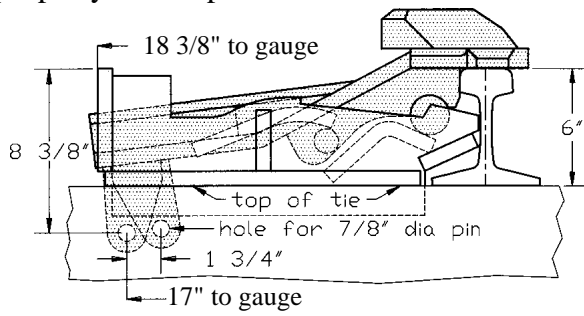

Model HB Size 6 on 6" Rail

figure 1

Figure 1 shows a size 6 derail. In this correct installation the derail is placed so that the surface under the horizontal tie flange of the guide box is just 6 inches below the top of the rail. With a size 5 derail this distance must be 5 inches, 7 inches for size 7 and 8 inches for size 8. Any Hayes derail can be made to accommodate a rail one-half inch lower to one-half inch higher than the size of the derail indicates by adapting the track to allow proper height placement.

Where the height of the rail in inches is the same as the size number of the derail both the rail and the derail are placed on the same surface. But, if the rail height is not the same as the size number of the derail, adjustment for height may be made by placing steel plates under the rail or the derail or by adzing the ties. Using steel plates is preferable. The use of standard tie plates, however, requires cutting them off at the base of rail on the gauge side. **The derail must set level and not cocked by the edge of tie plates or by out of level adzing.**

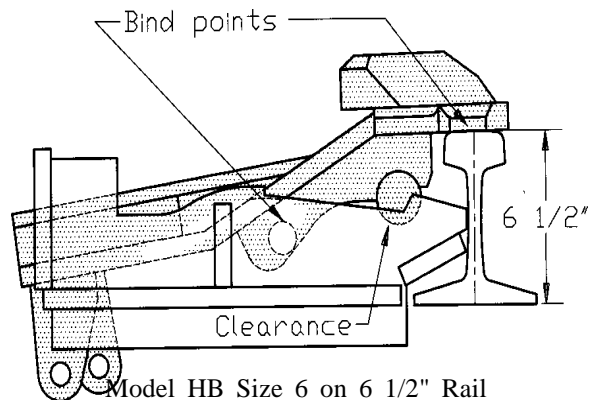

Model HB Size 6 on 6 1/2" Rail

figure 2

Figure 2 shows the result of trying to install a size 6 derail on a rail 6-1/2 inches high without properly adjusting the guide box 1/2 inch to make the surface on which the derail is secured 6 inches below the top of the rail.

Notice there is a binding between the head of the rail and the bearing points between the guide box and the block. There is also an unwanted clearance under the block thrust shaft and the guide box seat. The derail is designed to lift approximately one inch when being removed from the rail, when installed correctly. This lift creates a form of lock that resists removal of the derail under the car wheel.

When a derail is installed as fig. 2 illustrates, this lift is reduced and a free horizontal slide can occur that sets up the condition that the side pressure against the deflecting bar is unrestricted. The block can be shoved back into the guide box instead of derailing the car wheel.

The derail can also be damaged since forces are applied against parts not designed to absorb impact. In addition the derail may not cover the head of the rail because the full stroke of the derail is impeded by the binding of components before the derail was fully positioned.

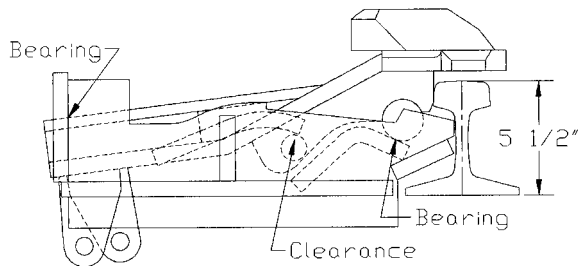

Model HB Size 6 on 5 1/2" Rail

figure 3

Figure 3 shows a size 6 derail installed on a rail 5-1/2 inches high without proper adjusting of the mounting surface. In this case the shoe is above the head of the rail. The internal design doesn't

allow for this much deviance from it's stated size. The derail was designed to have the weight of the car carried through the rail. The weight of a car is too much for any applied accessory to carry unless existing track components are employed.

The derail block is subject to deformation or breaking; the guide box can leverage the pulling of the spikes at the rear of unit as the car wheel forces the shoe down against the rail head as there is nothing to counteract the forces.

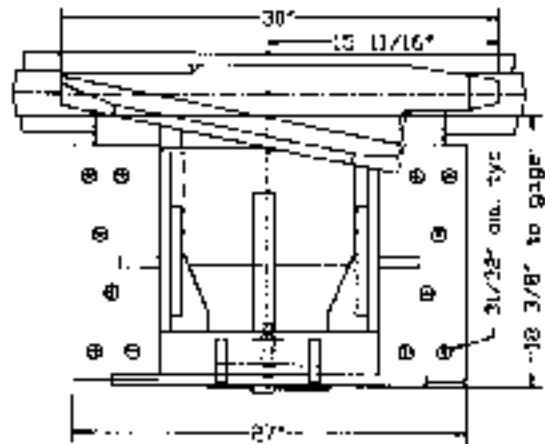

Model HB Right Hand Derail Plan View

figure 4

Right hand, left hand or bi-directional:

A single throw derail, figure 4, is recommended because it has a longer derailing surface with less angle of change for the wheel. Looking in the direction of movement of a car to be derailed, a right hand derail goes on the right rail, and derails toward the right; conversely with the left. Possible hazards or obstructions must be taken into consideration when selecting a derail's direction; buildings, walls, clearance points with other tracks and ditches must be avoided.

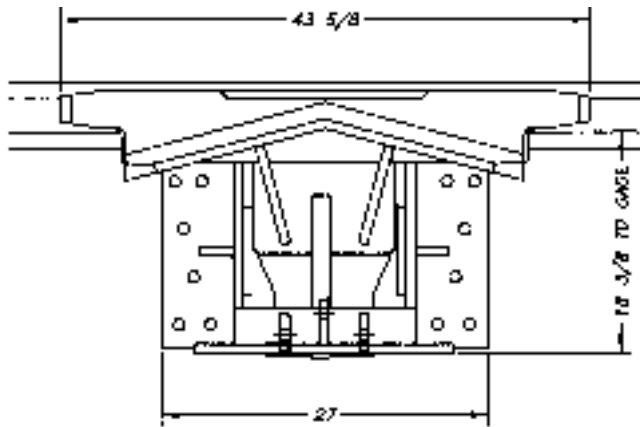

Model HBXS Plan View

figure 5

Bi-Directional:

Two-way derails, figure 5, will derail from either direction; therefore, they can be placed on either rail. Again, evaluate any incumbrances that may affect the derailing direction. The distance of the derail from the clearance point should be determined by the probable distance the car might run after being derailed. This depends on length of the track, the grade, soil and ballast conditions.

Derails on curves:

A derail should not be placed where the wheels have a tendency to bind against the opposite rail.

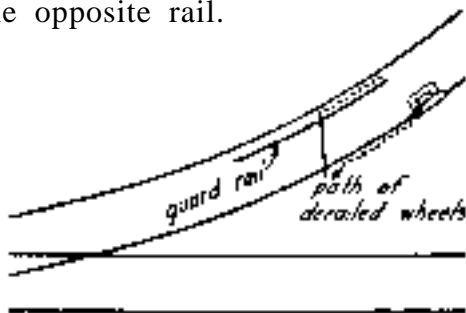

Correct Location of Derail On Curve

figure 6

Figure 6 should be followed where curves are encountered. Here, the straightest path for the wheels is allowed by placing the derail on the outside rail of the curve. Placing the derail on the rail against which the wheels tend to bind assists the derail in doing it's work, placing the derail on the opposite rail hinders derailment. Figure 7 shows an incorrect placement.

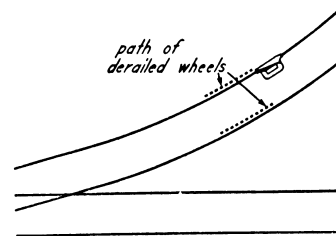

Incorrect Location of Derail on Curve

figure 7

Derail Wheel Crowder:

Special locations where it is absolutely necessary to derail to the inside rail of a curve or where higher speeds are anticipated, Western-Cullen-Hayes recommends the use of the Derail Wheel Crowder, figure 8, which assists derails by crowding the wheels into the throat or entering toe of the derail. This is significantly lower in cost than switch-point and stock rail type derails. Please write for information regarding its application and use.

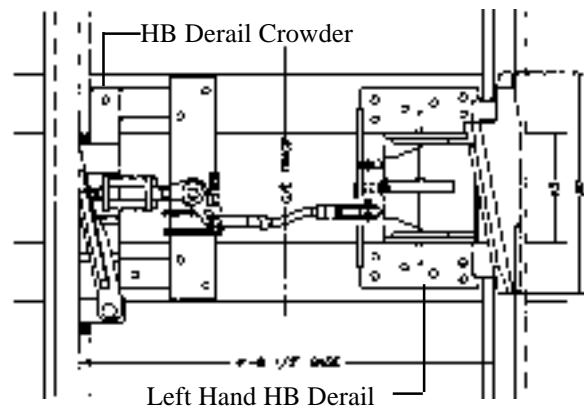
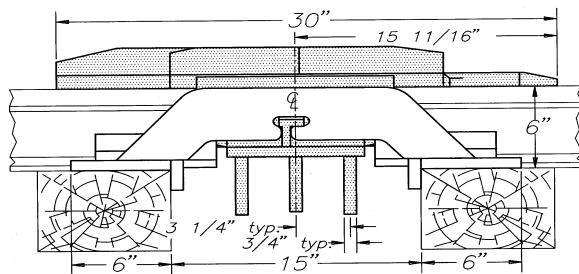

figure 8

Installing the Derail:

After determining the location of the derail and selecting the proper size and/or making proper accommodations for the size derail, the following should be reviewed: The ties should be sound and well tamped. Lay the derail in place. Shove the derail guide box against the web of the rail and fasten the guide box down to the ties. The heel end of the derail shoe should overhang a 3 inch rail head by 1/2 inch. When properly placed the derail block will drop neatly onto the top of the rail at the end of the forward stroke. The weight of the wheel will be carried through the derail block directly to the rail. If this does not occur, readjust the mounting of the guide box.



Rear View of HB Showing
Connecting Lugs and Dimensions

figure 9

Operating the Derail:

Operating and locking connections must be placed at right angles to the rail and in direct line with the movement of the derail block. A standard HB derail has a working stroke of 6-1/4 inches. To have a proper operation, this stroke must not be impeded.

There are HB's that have a special shorter stroke but they have a designation of "SS" affixed to the stainless steel nameplate and the serial number stamped in the top of the deflecting bar of the block.

Lubricate the derail as needed and be certain the guide box and the operating rods are not fouled by trash, ballast, blowing sand, ice or snow.

Inspection and Maintenance.

Derails should be given the same inspection and maintenance that other track and signal devices receive. Whenever the derail is encountered it should be inspected to ensure that all components are sound. The guide box should be securely fastened to the ties and the rail snug against the ties just as advised in the original installation procedure instructions.

The derail should be at a right angle to the rail and the derail shoe covering the rail head and overhanging a 3 inch wide head by at least 1/2 inch. If the efficiency of the derail is questioned please record the model and size derail; the rail section; track configuration; gauge of track; tie condition; vertical distance from top of rail to mounting surface of the derail guide box; also record spiking pattern and if spikes are seated. Each derail block is mated with the guide box. The serial number stamped on the top of the deflecting bar and the number stamped in the stainless steel nameplate on the guide box should match. Send us your findings and we will assist you in getting the results you expect.

WESTERN-CULLEN-HAYES, INC.
ARTICULATED AUTOMATIC MECHANICAL BLUE FLAG w/LIGHT (AAMBFL)
INSTALLATION FOR PART NO.'S 83111 (LEFT HAND) & 83112 (RIGHT HAND)

INSTRUCTIONS ARE TO BE USED IN CONJUNCTION
WITH DRAWING NO 83111 (AAMBFL PARTS & INSTALLATION)

1. Do not install AAMBFL until Derail, Operating Mechanism and Wheel Crowder (optional) have been installed per their respective installation instructions.
2. With the Derail in the On-rail position, place the AAMBFL according to the dimensions shown in FIG. 1 (dr. no. 83111). DO NOT FASTEN THE AAMBFL BASE TO THE TIE AT THIS TIME! Raise flag to a vertical position and attach the connecting rod (refer to FIG. 1 thru FIG. 3) and DO NOT SPREAD THE COTTER PINS IN THE CONNECTORS AT THIS TIME! The connecting rod eyebolt may require some adjustment. Align (square) the AAMBFL base with the attached connecting rod, while keeping the flag vertical.
3. CAREFULLY fasten the AAMBFL base to the ties, making sure that the power cord is not damaged. NOTE the loop at the bottom of the flag; it allows the flag to flex and must be maintained.
4. Slowly operate Derail to the Off-rail position. The flag should be near horizontal. If not, the AAMBFL base eyebolt (FIG. 4) will require adjusting and the readjustment of the connecting rod. This eyebolt controls the stroke of the unit. When all adjustments are finished spread the cotter pins.
5. Make electrical connections and install a bulb (not included-20 watts max). Operate unit to verify light operation.
6. Annually or as needed, grease unit.
7. The flag spring (FIG. 5) can stretch when severely abused and can be tightened as needed by tightening the spring eyebolt locknut at the bottom of the spring. When the spring can no longer be adjusted in this manner it should be replaced.

For more information contact: WESTERN-CULLEN-HAYES, INC.
P.O. BOX 756
RICHMOND, IN 47374
PHONE: 765-962-0526
FAX: 765-966-5374

83111 REV. 4

FIG. 1

PLAN VIEW
LEFT HAND INSTALLATION
RIGHT HAND IS OPPOSITE

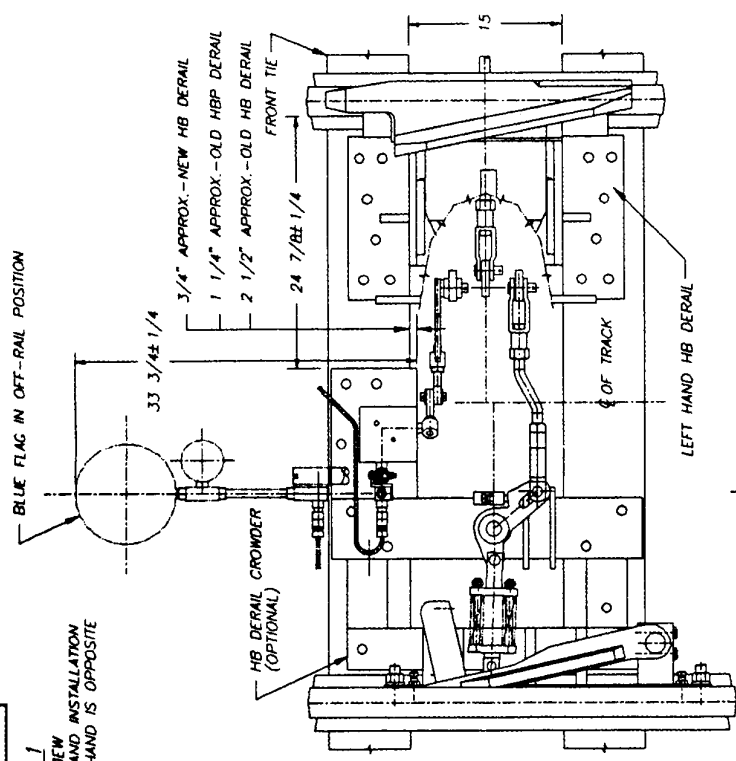
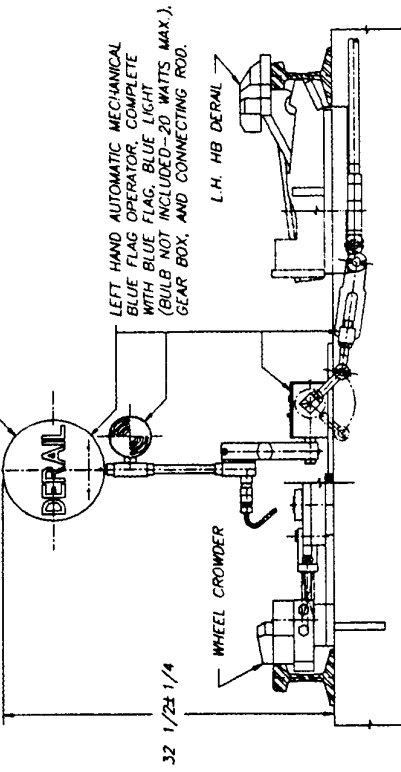

FIG. 2 REAR ELEVATION VIEW WITH REAR TIE REMOVED



C:\ACAD\DWG\83111\83111A

FIG. 5

FLAG STAFF COMPLETE
L.H. #83111-04 (SHOWN)
R.H. #83112-04

OPTIONAL FLAG STAFF WITHOUT LIGHT COMPLETE
L.H. #83111-05
R.H. #83112-05 SPECIFY WHEN ORDERING!

FLAG ASSEMBLY, L.H. SHOWN #83111-07-01, R.H. #83112-02-01
10" DIA. DK. BLUE SIGN W/WHITE LETTERING
FLAG ASSEMBLY INCLUDES: (BULB NOT INCLUDED)
MERCURY SWITCH FOR ON-OFF OPERATION
10 FT. OF OUTDOOR 16 GA. CORD

SPRING RETAINING BOLT & NUT: 3/8 NC X 2-1/2 HHCS AND
3/8 NC HEX NYLON INSERT LOCKNUT #83111-01-16.3
MIDDLE SPRING TUBE #83111-01-16.3
SPRING
SPRING EYEBOLT, 5/16 NC X 2
5/16 NC HEX NYLON INSERT LOCKNUT

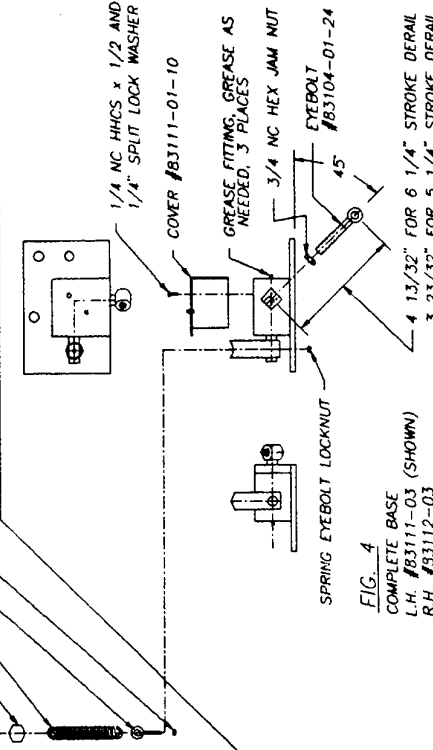
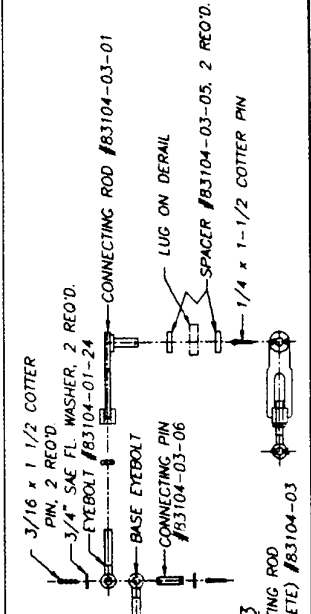

FIG. 4

COMPLETE BASE
L.H. #83111-03 (SHOWN)
R.H. #83112-03

FIG. 3



CONNECTING ROD (COMPLETE) #83104-03

REV.	DATE	BY	CHKD.	APP'D.	SCALE	SHEET	OF	REV. A
A	07-05-95	L.H.			1/8" = 1"	C		
B								
C								
D								
E								
F								
G								
H								
I								
J								
K								
L								
M								
N								
O								
P								
Q								
R								
S								
T								
U								
V								
W								
X								
Y								
Z								

WESTERN-CULLEN-HAYES, Inc.
THIS APPLICATED AUTOMATIC MECHANICAL BLUE FLAG W/ LIGHT (HAMB.) PARTS & INSTALLATION
HAS MADE IS THE PROPERTY OF WESTERN-CULLEN-HAYES, INC. AND SHALL NOT BE REPRODUCED, COPIED OR USED IN ANY MANNER DETRIMENTAL TO THEIR INTERESTS.

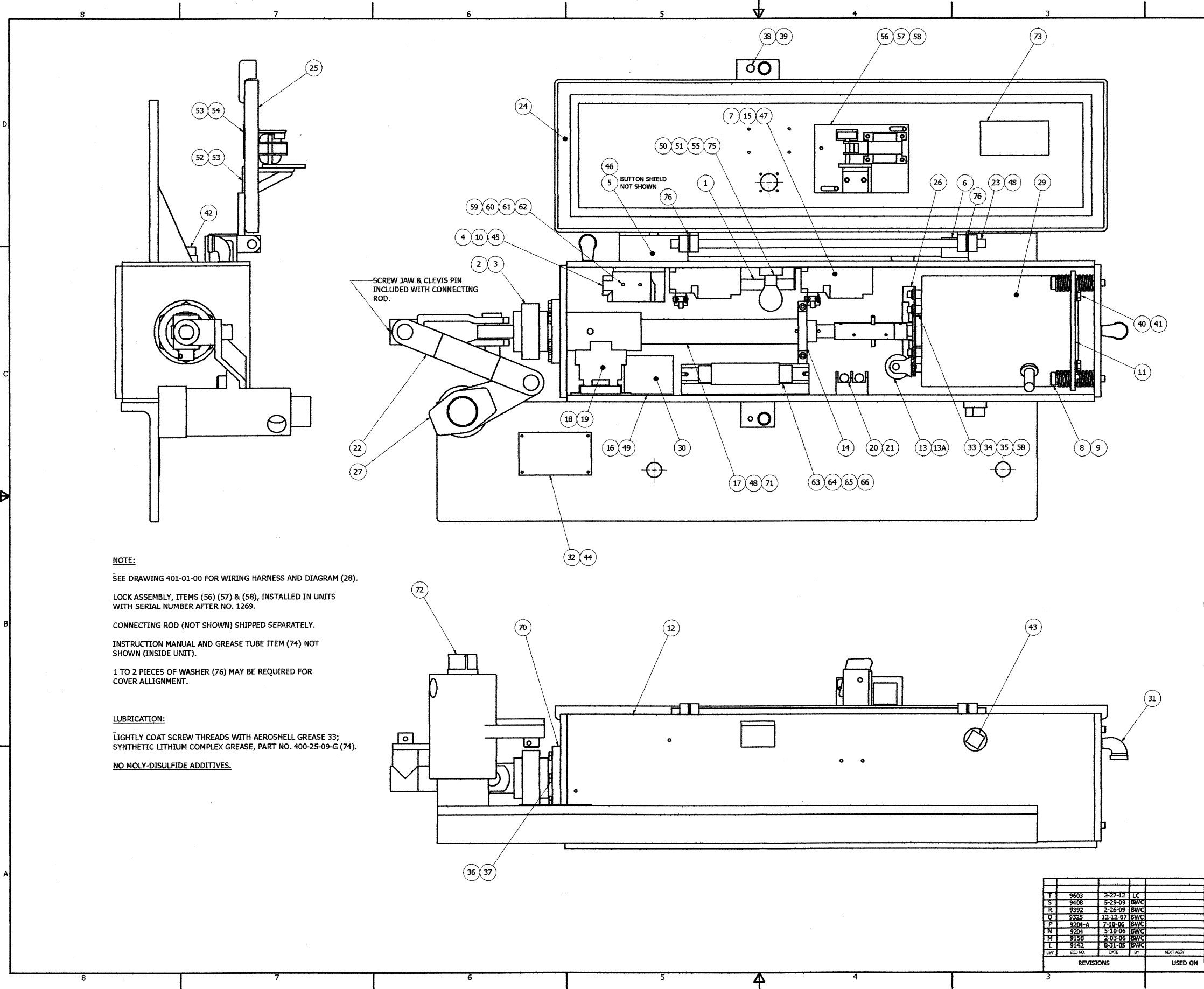

NOTE:
 SEE DRAWING 401-01-00 FOR WIRING HARNESS AND DIAGRAM (28).
 LOCK ASSEMBLY, ITEMS (56) (57) & (58), INSTALLED IN UNITS WITH SERIAL NUMBER AFTER NO. 1269.
 CONNECTING ROD (NOT SHOWN) SHIPPED SEPARATELY.
 INSTRUCTION MANUAL AND GREASE TUBE ITEM (74) NOT SHOWN (INSIDE UNIT).
 1 TO 2 PIECES OF WASHER (76) MAY BE REQUIRED FOR COVER ALIGNMENT.

LUBRICATION:
 LIGHTLY COAT SCREW THREADS WITH AEROSHELL GREASE 33; SYNTHETIC LITHIUM COMPLEX GREASE, PART NO. 400-25-09-G (74).
 NO MOLY-DISULFIDE ADDITIVES.

Parts List			
ITEM	QTY	PART NUMBER	DESCRIPTION
1	1	38-0045-286	RESISTIVE HEATER
2	2	400-03-00	HOSE CLAMP
3	1	400-04-00	PROTECTOR BOOT
4	1	400-08-00	SWITCH MOUNT ANGLE
5	1	400-09-00	SWITCH BUTTON SHIELD
6	1	400-11-00	EMERGENCY THROW LEVER
7	2	400-13-01	LIMIT SWITCH LEVER ARM
8	4	401-70-09	SHOULDER BOLT
9	8	401-70-08	BUFFER SPRING
10	1	400-06-00	INTERLOCK MICRO SWITCH
11	1	400-20-00	MOTOR MOUNTING PLATE
12	1	400-21-41	CASE ASSEMBLY
13	1	401-80-01	CAPACITOR
13A	1	401-80-02	CAPACITOR STRAP
14	1	400-25-22	GUIDE CLAMP
15	2	400-14-03	LIMIT SWITCH
16	1	400-28-00	CONTROL RELAY MOUNTING PLATE
17	1	400-25-16	TUBE ASSEMBLY
18	1	50-0954-F	FURNAS OVERLOAD RELAY
19	1	50-0955-F	FURNAS HEATER ELEMENT
20	1	50-0276	FUSE BLOCK - TWO POLE
21	2	400-35-05	15 AMP FUSE
22	1	400-37-04	OFFSET LINK ASSEMBLY
23	1	400-38-00	COVER PIN
24	1	400-39-00	WEATHER STRIP - 7/8 1/2 LG
25	1	400-43-06	COVER ASSEMBLY W/ LATCH
26	1	400-62-02	FRONT MOTOR SUPPORT
27	1	400-58-01	EMERGENCY THROW LEVER ARM
28	1	401-01-00	WIRING HARNESS & DIAGRAM
29	1	401-80-19	MOTOR & BALLSCREW ASSEMBLY
30	1	401-30-00	STRUTHERS DUNN CONTACTOR
31	2	1143-16-A	VENTILATOR ASSEMBLY
32	1	5612-38	NAME PLATE
33	4	401-70-03	MOTOR SUPPORT SPACER
34	4	BB-15-EE-3-01	1/4-20 x 1 SOCKET SCREW
35	4	PP-00-AJ-3	1/4 PLAIN WASHER
36	6	400-21-60	5/16-24 x 7/8 12 POINT BOLT
37	6	PP-00-AK-3	5/16 PLAIN WASHER
38	1	970-45	PUSH NUT
39	1	AA-12-GG-3-0062	5/16-18 x 5/8 HEX SCREW
40	4	AA-12-JJ-3-0075	3/8-16 x 3/4 HEX SCREW
41	4	RR-00-AM-3	3/8 LOCK WASHER
42	1	MC-126-00011	CARPLUG PIPE PLUG
43	2	1182-C	1" NPT PIPE PLUG
44	8	AS-10-AF-3-0025	#6 x 1/4 DRIVE SCREW
45	2	BB-15-DD-3-005	#10-32 x 1/2 SOCKET SCREW
46	2	AA-10-DD-3-0025	#10-32 x 1/4 ROUND HEAD SCREW
47	4	BB-15-DD-3-0175	#10-32 x 1 3/4 SOCKET SCREW
48	3	DD-48-DD-3-0025	#10-32 x 1/4 SET SCREW
49	2	BB-15-DD-3-0037	#10-32 x 3/8 SOCKET SCREW
50	1	1832-51	120 VOLT - 10 WATT LAMP
51	2	AA-10-BU-3-0075	#5-40 x 3/4 ROUND HEAD SCREW
52	1	416-17-00	WINDOW
53	8	AA-41-AA-3-0037	#6-32 x 3/8 THEFT PROOF MACH SCREW
54	1	5612-56	WARNING LABEL
55	1	90809	LAMP SOCKET
56	1	401-60-00	DELECTRIC LOCK ASSEMBLY
57	2	BB-15-EE-3-005	1/4-20 x 1/2 SOCKET SCREW
58	6	RR-00-AJ-3	1/4 LOCK WASHER
59	2	AA-10-AA-8-02	#6-32 x 2 ROUND HEAD SCREW
60	12	PP-00-AF-8	#6 PLAIN WASHER
61	2	RR-00-AF-3	#6 LOCK WASHER
62	2	JJ-12-AA-8	#6-32 HEX NUT
63	10	50-0154	TERMINAL
64	1	50-0155	TERMINAL END
65	1	50-0157	TERMINAL TRACK - 7 1/2 " LG
66	2	50-0156	TERMINAL CLAMP
70	1	416-09-00	TUBE MOUNT ASSEMBLY
71	1	5200	GREASE FITTING - 45 DEG
72	1	MC-126-00049	1" PIPE CAP
73	1	5612-61	ROTON LUBE LABEL
74	1	400-25-09-G	ROTON SCREW GREASE TUBE
75	1	90809-1	SOCKET INSULATOR
76	2	400-72-00	WASHER

INCLUDE 401-01-00 WIRING DIAGRAM WITH SHOP ORDERS.

<table border="1"> <tr><td>T</td><td>9603</td><td>2-27-12</td><td>LC</td></tr> <tr><td>S</td><td>9408</td><td>5-29-09</td><td>BW/C</td></tr> <tr><td>R</td><td>9392</td><td>2-26-09</td><td>BW/C</td></tr> <tr><td>Q</td><td>9325</td><td>12-12-07</td><td>BW/C</td></tr> <tr><td>P</td><td>9204-A</td><td>7-10-06</td><td>BW/C</td></tr> <tr><td>N</td><td>9204</td><td>5-10-06</td><td>BW/C</td></tr> <tr><td>M</td><td>9158</td><td>2-03-06</td><td>BW/C</td></tr> <tr><td>L</td><td>9142</td><td>8-31-05</td><td>BW/C</td></tr> <tr><td>REV</td><td>EDD:ND</td><td>DATE</td><td>BY</td></tr> </table>	T	9603	2-27-12	LC	S	9408	5-29-09	BW/C	R	9392	2-26-09	BW/C	Q	9325	12-12-07	BW/C	P	9204-A	7-10-06	BW/C	N	9204	5-10-06	BW/C	M	9158	2-03-06	BW/C	L	9142	8-31-05	BW/C	REV	EDD:ND	DATE	BY	<table border="1"> <tr><td>REVISIONS</td><td>USED ON</td></tr> </table>	REVISIONS	USED ON	<p>1. UNLESS OTHERWISE SPECIFIED DIMENSIONS ARE IN INCHES TOLERANCE ON MACHINED DIMENSIONS</p> <p>DECIMALS XX +/- .010 XXX +/- .005</p> <p>FRACTIONS +/- 1/64 ANGLES +/- 1/2 DEG</p> <p>2. REMOVE ALL BURRS</p>	<table border="1"> <tr><td>DRAWN</td><td>DATE</td><td>WESTERN CULLEN HAYES, INC.</td></tr> <tr><td>J.B.</td><td>1-12-78</td><td>2700 WEST 36th PLACE - CHICAGO, IL 60632-1682</td></tr> <tr><td>TITLE</td><td></td><td>DELECTRIC OPERATOR</td></tr> <tr><td>APPRO</td><td>DATE</td><td>THIS DRAWING IS THE PROPERTY OF WESTERN CULLEN HAYES, INC. AND SHALL NOT BE REPRODUCED, COPIED OR USED IN ANY MANNER PERMISSIBLE TO THEIR INTERESTS</td></tr> <tr><td>SCALE</td><td>SIZE</td><td>SHEET PART NUMBER</td></tr> <tr><td>3/8</td><td>D</td><td>OF 401-00-01</td></tr> </table>	DRAWN	DATE	WESTERN CULLEN HAYES, INC.	J.B.	1-12-78	2700 WEST 36th PLACE - CHICAGO, IL 60632-1682	TITLE		DELECTRIC OPERATOR	APPRO	DATE	THIS DRAWING IS THE PROPERTY OF WESTERN CULLEN HAYES, INC. AND SHALL NOT BE REPRODUCED, COPIED OR USED IN ANY MANNER PERMISSIBLE TO THEIR INTERESTS	SCALE	SIZE	SHEET PART NUMBER	3/8	D	OF 401-00-01
T	9603	2-27-12	LC																																																								
S	9408	5-29-09	BW/C																																																								
R	9392	2-26-09	BW/C																																																								
Q	9325	12-12-07	BW/C																																																								
P	9204-A	7-10-06	BW/C																																																								
N	9204	5-10-06	BW/C																																																								
M	9158	2-03-06	BW/C																																																								
L	9142	8-31-05	BW/C																																																								
REV	EDD:ND	DATE	BY																																																								
REVISIONS	USED ON																																																										
DRAWN	DATE	WESTERN CULLEN HAYES, INC.																																																									
J.B.	1-12-78	2700 WEST 36th PLACE - CHICAGO, IL 60632-1682																																																									
TITLE		DELECTRIC OPERATOR																																																									
APPRO	DATE	THIS DRAWING IS THE PROPERTY OF WESTERN CULLEN HAYES, INC. AND SHALL NOT BE REPRODUCED, COPIED OR USED IN ANY MANNER PERMISSIBLE TO THEIR INTERESTS																																																									
SCALE	SIZE	SHEET PART NUMBER																																																									
3/8	D	OF 401-00-01																																																									