



## **THE 3597 GATE MECHANISM FROM WESTERN-CULLEN-HAYES, INC.**

U.S. Patent 6,307,339

The 3597 offers the same proven reliability as previous Western-Cullen-Hayes mechanisms but with the added performance of our patented Electronic Gate Monitor (EGM), and a new high torque permanent magnet motor.

The Electronic Gate Monitor protects the mechanism from damage if:

- The counterweights crash after the gate arm is knocked off.
- The gate arm crashes down caused by loss of power.
- The gate arm pumps.
- The motor overloads due to an obstructed gate arm.

The Model 3597 also features, as standard, a power down and test switch that operates the mechanism to the horizontal position without a gate arm in place. This switch enables signal maintenance personnel to replace a damaged gate arm safely.

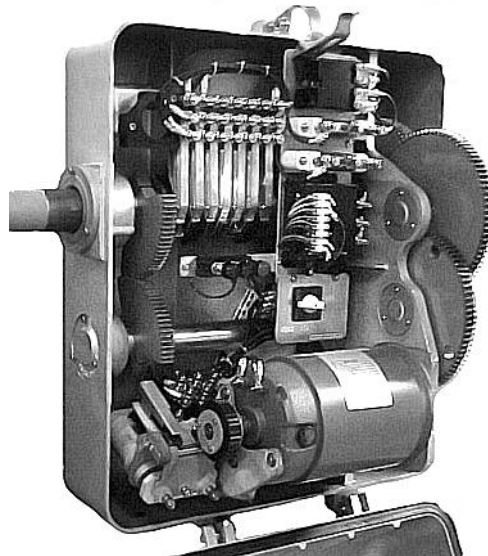

The set up and service of the 3597 is quite different than any other mechanism. Carefully read and follow the instructions in this manual to insure the proper set up and operation of the 3597 Gate Mechanism.

## SECTION 1

### TECHNICAL SEQUENCE OF OPERATION AND FIELD WIRING REQUIREMENTS

Electronic Gate Monitor (EGM) Description:

The Western-Cullen-Hayes, Inc. Model 3597 Gate Mechanism incorporates an Electronic Gate Monitor (EGM) System that protects against damage to the gate mechanism when common failure conditions occur.

The EGM operates by sensing voltage. If conditions exist that enables the dc mechanism motor to generate electricity, the EGM will sense the generated voltage which is greater than the normal dc power supply. When this over voltage condition occurs, the EGM de-energizes the two internal relays. A second circuit exists that accumulates voltage during normal, pumping and gate obstruction conditions. When the accumulated voltage reaches a certain threshold, the EGM de-energizes the two relays and connects the braking circuit.

Nominal 12 vdc is supplied to the EGM by connecting the red (positive) wire lead to terminal 2A located on the mechanism circuit controller. A black (negative) wire is connected to terminal 4 on the cam switch "C". When power is present, a red LED indicator on the EGM illuminates.

When conditions are normal, the EGM relays are energized and a green LED indicator on the EGM illuminates. When a failure has occurred to cause the EGM to de-energize the relays, the green LED goes dark.

There are three 1/4" studs on the EGM that are for connecting the main control relay outputs to the motor and the shorting resistor. The relay provides one set of Form C contacts (SPDT). Terminal common connects to motor terminal B, normally open connects to the cam switch and normally closed connects to the shorting resistor. During normal operation the voltage path is through the normally open contacts of the relay. During a fault event, the relay de-energizes and connects motor terminal A to the shorting resistor and back to motor terminal B which completes the dynamic braking circuits.

A second SPDT relay is provided within the EGM to annunciate that a fault condition has occurred and the EGM has operated. Three terminal connections are provided for customer connection to this feature. (ANC, ANO, ACOM).

The orange wire lead is connected to motor terminal A. The yellow lead is connected to terminal 12 on the cam switch and then connected to motor terminal B. The two voltage monitoring systems within the EGM are fed from these wires.

The blue wire lead is connected to terminal 2B on the mechanism circuit controller. This wire provides the path of voltage to reset the EGM after a fault has occurred. The reset signal is sent to the EGM each time a gate clear command is received from the control case. A fault condition can also be reset by the push-button located on the EGM.

### **Normal 3597 Gate Mechanism Operation:**

Mechanism operating voltage is 12 vdc nominal. Supply voltage should be maintained between 11 and 16 volts DC.

Voltage at the circuit controller terminals should not drop below 11 vdc during normal operations, or drop below 9 volts during lifting of weights, vertical mechanism pumping or mechanism obstruction. Positive voltage is applied to terminal 2A and negative is applied to terminal 7A on the circuit board. Mechanism control voltage is connected to terminal 2B on the circuit board. For 3597 mechanisms equipped with the PC Relay Board, positive voltage is applied to terminal 3A, and mechanism control voltage is connected to terminal 2A.

### **Gate Up Operation:**

Static Position: Gate horizontal (down).

Contact Position: #1 normally closed (back) gate power down contact open, #1 normally open (front) gate snub down contact closed, #2 power up closed, #3 gate down closed, #4 gate clear open, #5 bell silence contact open, #6 spare open, #7 snub closed, hold clear power down contact closed.

When mechanism control voltage is applied, and if the cam switch "C" is in the run position, the pick coil of the hold clear energizes thus engaging the hold clear mechanism and opening the hold clear mounted power down contact. Voltage then flows through the cam operated power up contact (#2). This allows the hold coil of the hold clear to energize as well as the motor control relay (MCR). When the MCR energizes, positive voltage is applied to motor terminal A and negative is connected to motor terminal B, the motor starts and the gate raises under full power. When the main shaft of the mechanism reaches a point, normally 85 to 90 degrees, the #2 contact opens, the pick coil of the hold clear and the MCR de-energizes and the motor stops. As long as control voltage is supplied, the hold coil of the hold clear remains energized and the hold clear and ratchet wheel attached to motor holds the gate in the adjusted vertical position.

### **Gate Down Operation:**

Static Position: Gate vertical (up).

Contact Position: #1 normally closed (back) gate power down contact closed, #1 normally open (front) gate snub down contact open, #2 power up open, #3 gate down open, #4 gate clear closed, #5 bell silence contact closed, #6 spare open, #7 snub open, hold clear down contact open.

When mechanism control voltage is removed, the hold clear de-energizes and the hold clear power down contact closes. Voltage travels through the closed #1 power down contact, the snub resistor and the contacts of the de-energized MCR to the motor. The motor powers the gate down until the #1 normally closed power down contact opens and power is removed from the motor. The #1 normally open snub down contact then closes allowing motor generated voltage to travel through the MCR contacts and the adjustable resistor creating dynamic breaking. This breaking slows and controls the decent of the gate. When the gate arm is almost horizontal, the #7 snub contact closes creating an short between the motor terminals. The gravitational weight of the gate arm then forces the gate to slowly descend the final degrees and the arm rests in the horizontal position.

### **Manual Electric Gate Down Operation:**

When mechanism control voltage is present at the circuit controller terminal and the gate is in the vertical position, the gate can be lowered by operating the cam switch to the test position. The gate descends to the horizontal position. When the cam switch is operated to the run position, and the reset button on the EGM is depressed, the gate will operate to the vertical position as described under gate up operation. This operation is also a test of the EGM. The gate can also be lowered by loosening the gold test nut located at terminal 2B on mechanisms equipped with the PC Relay Board.

### **EGM Controlled and Annunciated Fault Operations of the 3597 Gate Mechanism:**

#### **Gate Arm Knocked-Off Operation:**

If the gate arm is knocked off in any position except the vertical position, the force of gravity pulls the counterweights violently downward. If this condition occurs, the EGM senses a sharp increase in voltage being generated by the forced rotation of the motor. The relays in the EGM de-energize, the green LED will go dark and dynamic breaking, through external wiring within the 3597 mechanism, controls the descent of the weights and protects against damage to the mechanism. The dynamic braking is accomplished by shorting the A and B terminals of the motor through an adjustable resistor.

#### **Gate Arm Guillotine Operation:**

If mechanical or electrical failure occurs causing the attached gate arm to violently drop from the vertical to horizontal position, the EGM senses a sharp increase in voltage being generated by the forced rotation of the motor. The relays in the EGM de-energize, the green LED will go dark and dynamic breaking, through external wiring within the 3597 mechanism, controls the descent of the gate arm and prevents damage to mechanism and gate arm.

#### **Open Electrical Circuit Failure:**

The gate mechanism could display the operational characteristics of the gate arm being knocked off or guillotine operation if an open failure in the mechanism electrical circuit were to occur, such as a relay contact not making contact, open snub resistor or an open condition in the wiring. When such an event happens, the EGM will control the fault the same as described for the knock-off guillotine operations provided the EGM is connected and there are not any openings in the EGM circuit, the shorting resistor or the motor. Supply power does not have to be present at the EGM for it to control a fault.

#### **Vertical Gate Arm Pumping Operation:**

If a mechanical or electrical failure of the hold clear device or ratchet wheel occurs, the gate arm will oscillate (pump) in the vertical position. When this happens, the motor powers the gate until #2 power up contact opens. If the gate cannot be mechanically held in the vertical position, the force of gravity causes the arm to begin to descend, the #2 contact closes, power is applied to the motor and the gate is driven back to vertical. This series of events continuously repeats. Each time a pulse of voltage is received at the motor, a certain amount of voltage is stored within the EGM. When the stored voltage reaches a threshold, the EGM de-energizes it's relays, the green LED goes dark, the pumping ceases and the gate arm descends to horizontal position through the controlled dynamic breaking circuit. The gate arm will remain in the horizontal position until the EGM receives a pulse of 12 vdc positive voltage at the reset wire lead, created by a gate up command sent from the external crossing control system, or, the manual reset button located on the EGM is depressed. When reset, the green LED illuminates.

**Horizontal Gate Arm Pumping Operation:**

After a gate arm has been knocked off (refer to Gate Arm Knocked Off Operation) the gateless counterweight assembly will rest anywhere from 50 to 80 degrees vertical. After a crossing system commands the gate to raise to vertical, the EGM relays energize, the 3597 goes into normal gate up operation and the motor powers the mechanism to vertical position. When a gate down command is received from the crossing control system, the counterweight assembly may oscillate (pump) towards the horizontal position.

The gateless counterweight assembly powers down until the #1 normally closed power down contact opens. When the contact opens, the counterweights begin to descend the #1 normally closed contact closes again and repowers the unit. This series of events continuously repeats. Each time a pulse of voltage is received at the motor, a certain amount of the voltage is stored within the EGM. When the stored voltage reaches a threshold, the EGM de-energizes it's relays, the green LED will go dark, the pumping ceases and the gateless counterweight assembly comes to rest. The assembly will remain in this position until the EGM receives a pulse of 12 vdc positive voltage at the reset wire lead, created by a gate up command sent from the external crossing control systems, or the manual reset button located on the EGM is depressed. When reset the green LED illuminates. The mechanism then goes into normal gate up operation and the motor powers the mechanism to the vertical position.

**Gate Hang-Up Failure Operation:**

If for any reason the gate arm becomes obstructed while clearing power is applied to the motor, after a period of time the EGM will de-energize it's relay to prevent electrical component burn-up. When power is applied to the motor, a certain amount of the voltage is stored within the EGM. When the stored voltage reaches a threshold, the EGM de-energizes it's relays, the green LED goes dark and power is removed from the motor. If the gate has been obstructed while traveling from the horizontal to vertical position, the hold clear device is energized. When the EGM removes motor power and the hold clear is energized, the gate will rest at the point which power was removed from the motor. If the gate has been obstructed by vandals hanging on the gate, the gate will rest at the position it was in when the EGM de-energized. If the gate is obstructed by a light unit or information sign which has been moved from normal position or by a misaligned hi-wind bracket, the gate will rest the position it was in when the EGM de-energized. Once a gate down command is received from the crossing control system, the gate will gravity down to the horizontal position, if the obstruction is not such as to hold the gate arm in the obstructed position. Once a gate up command is received from the crossing control system, the gate will operate to the vertical position as normal, or if the obstruction still exists, the hang-up sequence will repeat.

If the gate rests in a traffic obstruction position, it is possible to manually raise the gate to higher position by walking the gate up by hand. The gate will then hold in the repositioned location.

**EGM Operation Annunciation:**

Whenever the EGM de-energizes due to any of the described fault events, and the user has connected the EGM to external logic or recording devices, the auxiliary relay contacts will transfer and send an indication to the external device that a fault has been controlled.

The green LED will be dark when the EGM is in the fault mode. When reset, the relays energize and the green LED illuminates.

## **3597 Gate Mechanism Arm Service Operation:**

### **Gate Arm Service (Power Down) Mode:**

When a gate arm is knocked off, and the controlled gate arm knock-off operation has completed, the counterweights and the gate arm adapter channel rest in a mostly vertical position. It is necessary to position this assembly in the horizontal position to install a replacement gate arm. The 3597 incorporates a three position rotary contactor for this purpose. In the run position, the gate operates normally and the EGM is connected into the circuit.

In the test position, the circuitry is disconnected from the motor and the EGM is connected to the circuit. In the down position, full power down is applied to the motor to drive the counterweights to the horizontal position. In this position the EGM is disconnected from the circuits. The counterweights are held in the horizontal position via a 1/2" ratchet wrench with 7/8" socket. When the contactor switch is released, it automatically spring returns to the test position and places the EGM back into the circuit. See page 32 for specific instructions.

The service mode of the 3597 mechanism allows for a total of 12, forty-seven pound counterweights (required for a 40 foot gate) to be operated when a minimum of 11 vdc power is maintained at the mechanism motor.

## Wiring Requirements.

The 3597 mechanism will draw up to 55 amps when it is obstructed and up to 40 amps while lifting weights. **To allow proper mechanism operation, wire size for the motor power circuit must be calculated so that voltage does not drop below 11 vdc during normal operations, or drop below 9 vdc during lifting of weights, vertical mechanism pumping or mechanism obstruction.**

**Do not install #9 or #10**

**wire at any point in the motor power circuit.** Refer to the following example and formulas.

### VOLTAGE DROP EXAMPLES AT 55 AMP LOCKED ROTOR CURRENT

WIRE LENGTH IN FEET	VOLTAGE DROP USING 1-#6 CABLE	PERCENT DROP @ 12 V SUPPLY	PERCENT DROP @ 15 V SUPPLY
50	2.3	19.16	15.33
100	4.6	38.33	30.66
150	6.9	57.5	46
200	9.2	76.6	61.3

WIRE LENGTH IN FEET	VOLTAGE DROP USING 2-#6 CABLE	PERCENT DROP @ 12 V SUPPLY	PERCENT DROP @ 15 V SUPPLY
50	1.15	9.58	7.66
100	2.3	19.16	15.33
150	3.45	28.75	23
200	4.1	34.16	27.33

WIRE LENGTH IN FEET	VOLTAGE DROP USING 3-#6 CABLE	PERCENT DROP @ 12 V SUPPLY	PERCENT DROP @ 15 V SUPPLY
50	0.76	6.33	5.06
100	1.53	12.75	10.2
150	2.3	19.16	15.33
200	3.06	25.5	20.4

WIRE LENGTH IN FEET	VOLTAGE DROP USING 1-3/16" BOND STRAND	PERCENT DROP @ 12 V SUPPLY	PERCENT DROP @ 15 V SUPPLY
10	0.35	2.91	2.33

WIRE LENGTH IN FEET	VOLTAGE DROP USING 1-#10 WIRE	PERCENT DROP @ 12 V SUPPLY	PERCENT DROP @ 15 V SUPPLY
10	1.17	9.75	7.8

TO CALCULATE OTHER LENGTHS OF RUN USE THE FOLLOWING FORMULA.

$$\frac{22 \times \text{WIRE LENGTH IN FEET} \times 55}{\text{CIRCULAR MILS}}$$

WIRE SIZE	CIRCULAR MILS	WIRE SIZE	CIRCULAR MILS
#10	10400	#4	41700
#9	13100	#2	66400
#6	26300		

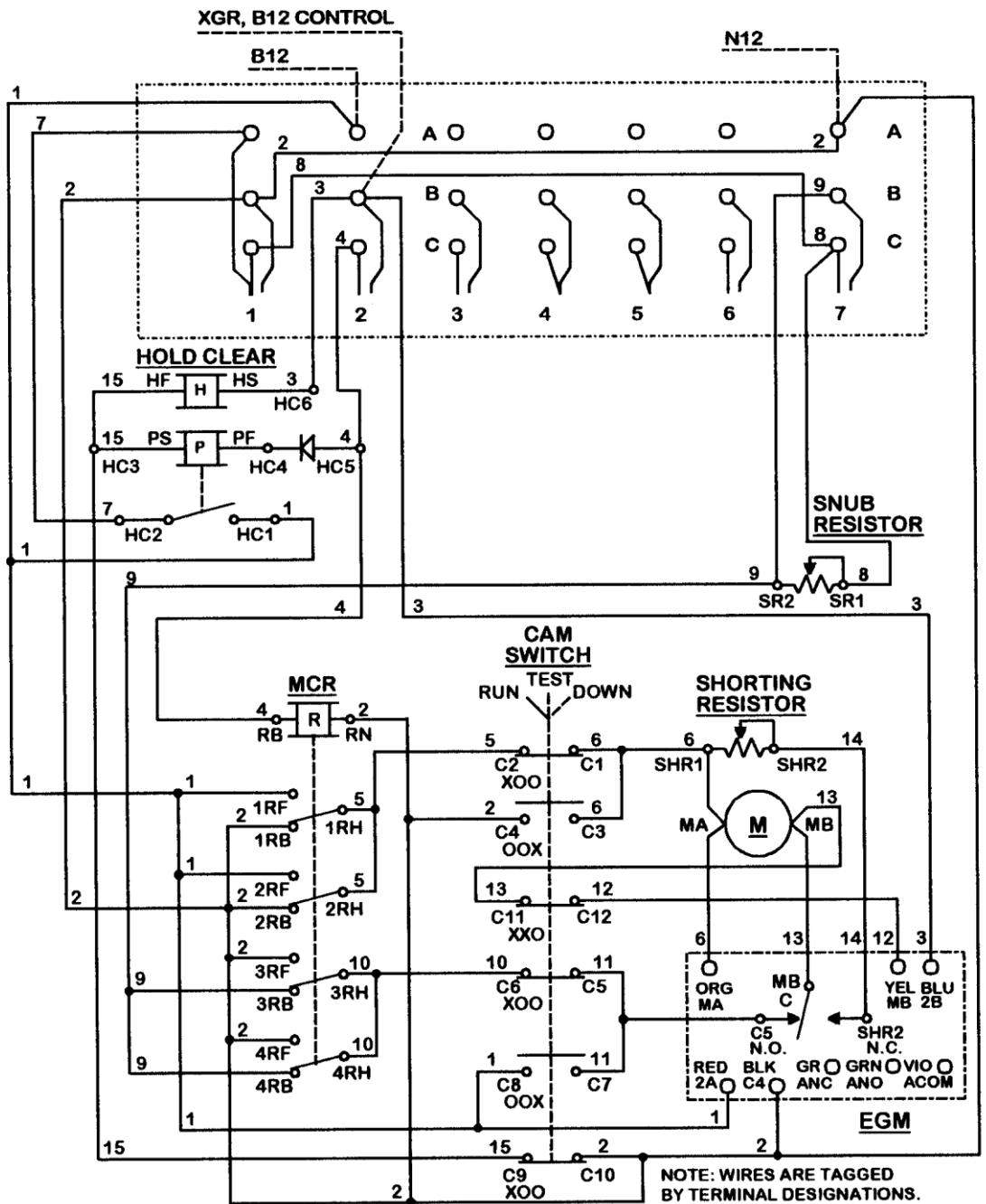

SHOWN WITH GATE IN CLEAR POSITION, EGM NORMAL & ENERGIZED AND CAM SWITCH IN THE RUN POSITION.

CONTACT	CLOSED	FUNCTION	TENSION
1B	75-90 DEG.	POWER DOWN	18-28 OZ.
1F	0-70 DEG.	SNUB DOWN	18-28 OZ.
2	0-86 DEG.	POWER UP	18-28 OZ.
3	0-10 DEG.	GATE DOWN	16-24 OZ.
4	82-90 DEG	GATE CLEAR	16-24 OZ.
5	10-90 DEG.	BELL	16-24 OZ.
6		SPARE	16-24 OZ.
7	0-2 DEG	SNUB	16-24 OZ.

**WESTERN-CULLEN-HAYES, INC.**  
**3597 GATE MECHANISM WITH**  
**ELECTRONIC GATE MONITOR**  
**WIRING DIAGRAM 3597-WD**  
**REV. D, 11/28/01, ECO 8736**

U.S. PATENT 6,307,339

**MANUFACTURE DISCONTINUED 12/02**



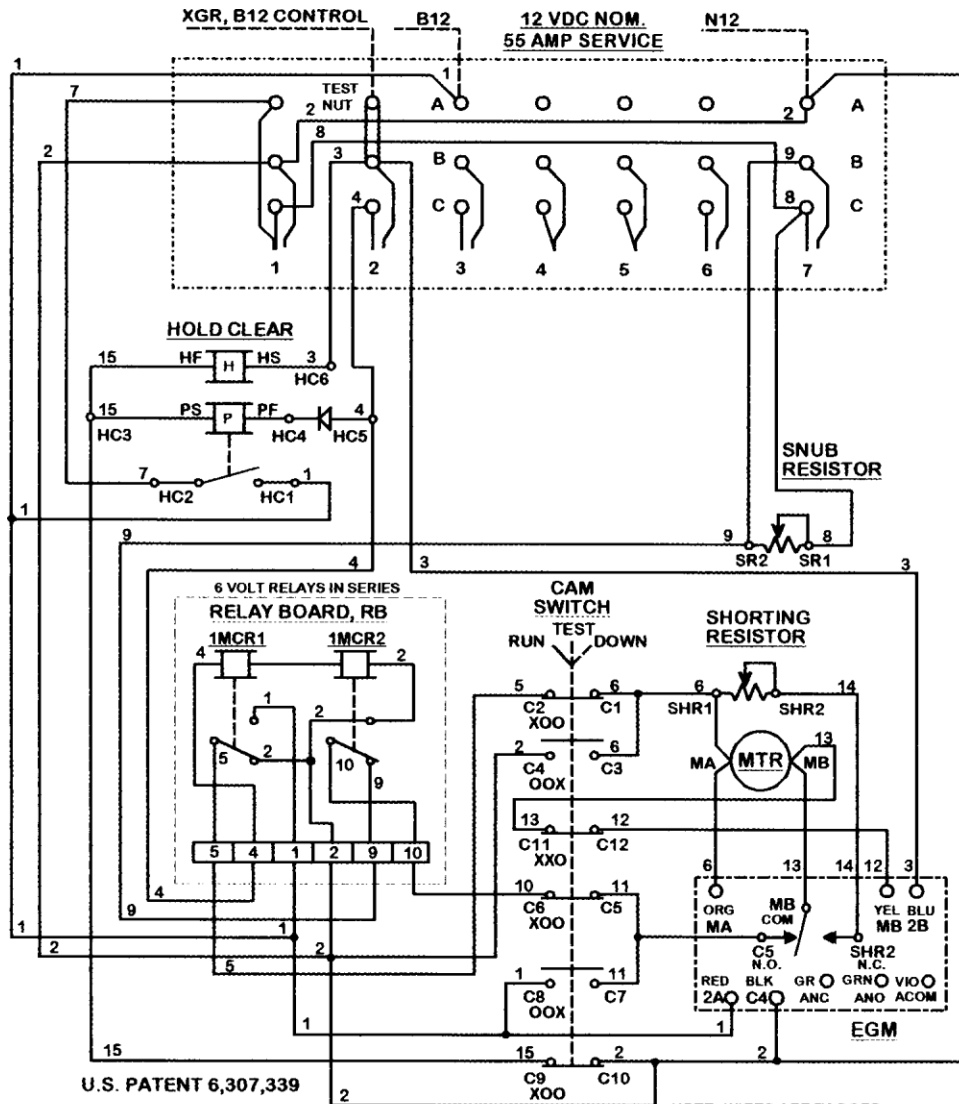

U.S. PATENT 6,307,339

SHOWN WITH GATE IN CLEAR POSITION, EGM NORMAL & ENERGIZED AND CAM SWITCH IN THE RUN POSITION.

NOTE: WIRES ARE TAGGED BY TERMINAL DESIGNATIONS. WIRE NUMBERS SHOWN ONLY FOR EASE OF CIRCUIT TROUBLESHOOTING.

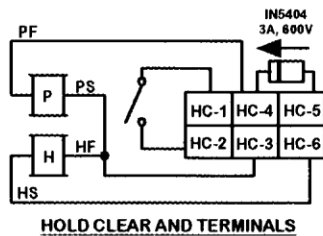

HOLD CLEAR AND TERMINALS

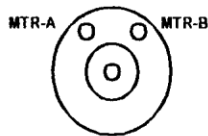

MOTOR TERMINALS VIEWED FROM HOLD CLEAR END.

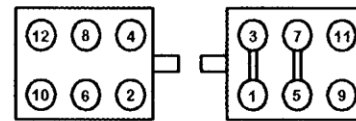

LEFT SIDE

RIGHT SIDE

CAM SWITCH TERMINALS

CONTACT	CLOSED	FUNCTION	TENSION
1B	75-90 DEG.	POWER DOWN	18-28 OZ.
1F	0-70 DEG.	SNUB DOWN	18-28 OZ.
2	0-86 DEG.	POWER UP	18-28 OZ.
3	0-10 DEG.	GATE DOWN	16-24 OZ.
4	82-90 DEG	GATE CLEAR	16-24 OZ.
5	10-90 DEG.	BELL	16-24 OZ.
6	SPARE	SPARE	16-24 OZ.
7	0-2 DEG	SNUB	16-24 OZ.

**WESTERN-CULLEN-HAYES, INC.**  
**3597 GATE MECHANISM WITH**  
**ELECTRONIC GATE MONITOR**  
**AND PC RELAY BOARD.**

**WIRING DIAGRAM 3597-WD-RB.**  
**4/17/02, ECO 8782B**

**MANUFACTURE DISCONTINUED 02/2005**

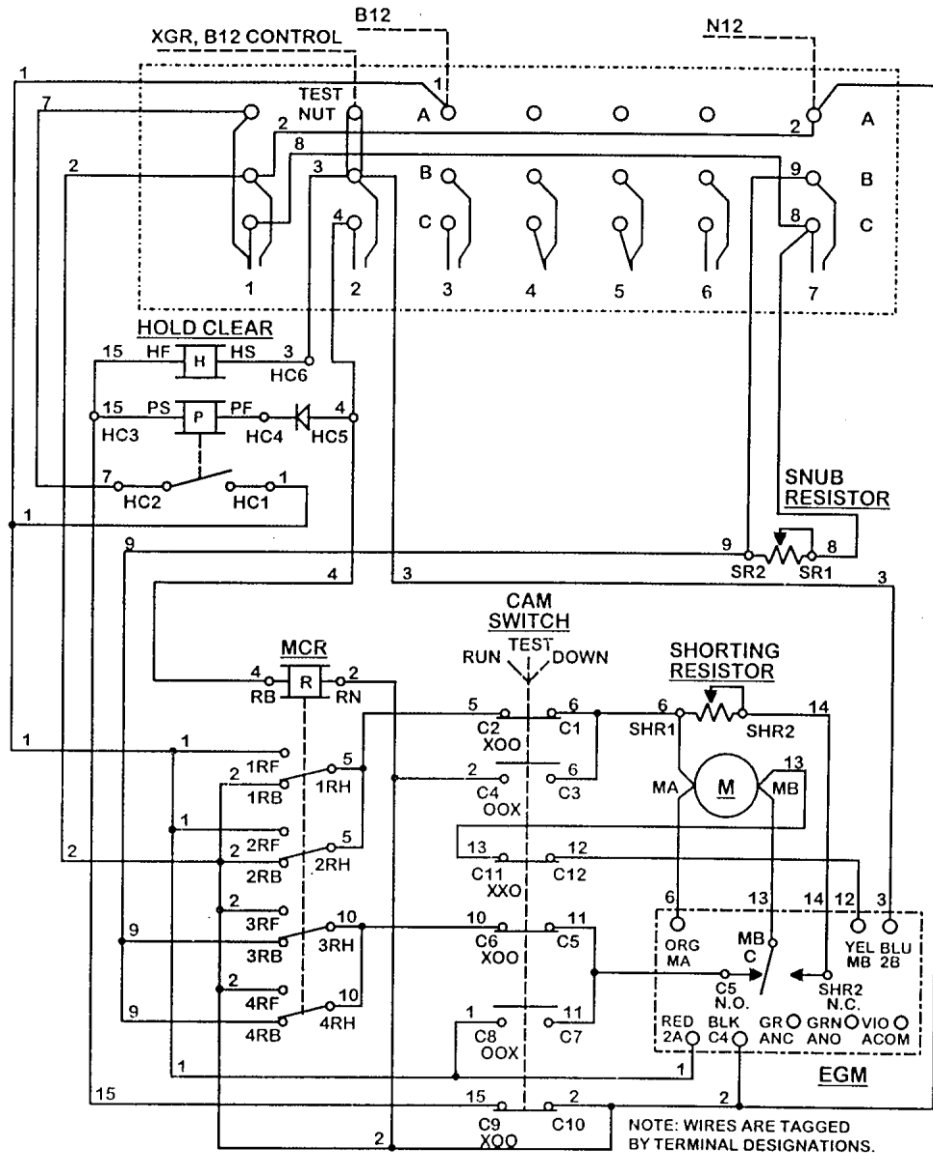

NOTE: WIRES ARE TAGGED BY TERMINAL DESIGNATIONS. WIRE NUMBERS SHOWN ONLY FOR EASE OF CIRCUIT TROUBLESHOOTING.

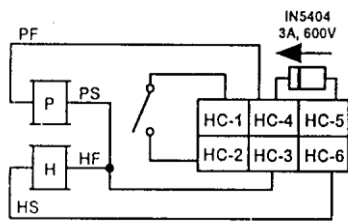

HOLD CLEAR AND TERMINALS

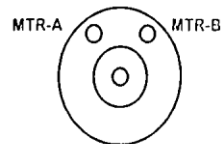

MOTOR TERMINALS VIEWED FROM HOLD CLEAR END.

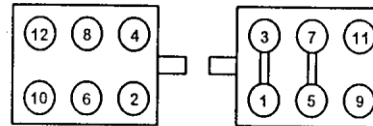

LEFT SIDE CAM SWITCH TERMINALS  
RIGHT SIDE

SHOWN WITH GATE IN CLEAR POSITION, EGM NORMAL & ENERGIZED AND CAM SWITCH IN THE RUN POSITION.

CONTACT	CLOSED	FUNCTION	TENSION
1B	75-90 DEG.	POWER DOWN	18-28 OZ.
1F	0-70 DEG.	SNUB DOWN	18-28 OZ.
2	0-86 DEG.	POWER UP	18-28 OZ.
3	0-10 DEG.	GATE DOWN	16-24 OZ.
4	82-90 DEG	GATE CLEAR	16-24 OZ.
5	10-90 DEG.	BELL	16-24 OZ.
6	SPARE	SPARE	16-24 OZ.
7	0-2 DEG	SNUB	16-24 OZ.

**WESTERN-CULLEN-HAYES, INC.**  
**3597 GATE MECHANISM WITH**  
**ELECTRONIC GATE MONITOR**  
**AND TEST NUT.**

**WIRING DIAGRAM 3597-WD.**  
 REV. E, 2/18/2005, ECO 9086

U.S. PATENT 6,307,339

draw4mechslm1013597\3597-wd.ds4

**This Page Left Blank Intentionally**

## SECTION 2 INSTALLATION INSTRUCTIONS - MODEL 10 SIGNAL

1. Install foundation in proper location per the requirements of the installation. Refer to figures 1 and 2 for typical foundation details.

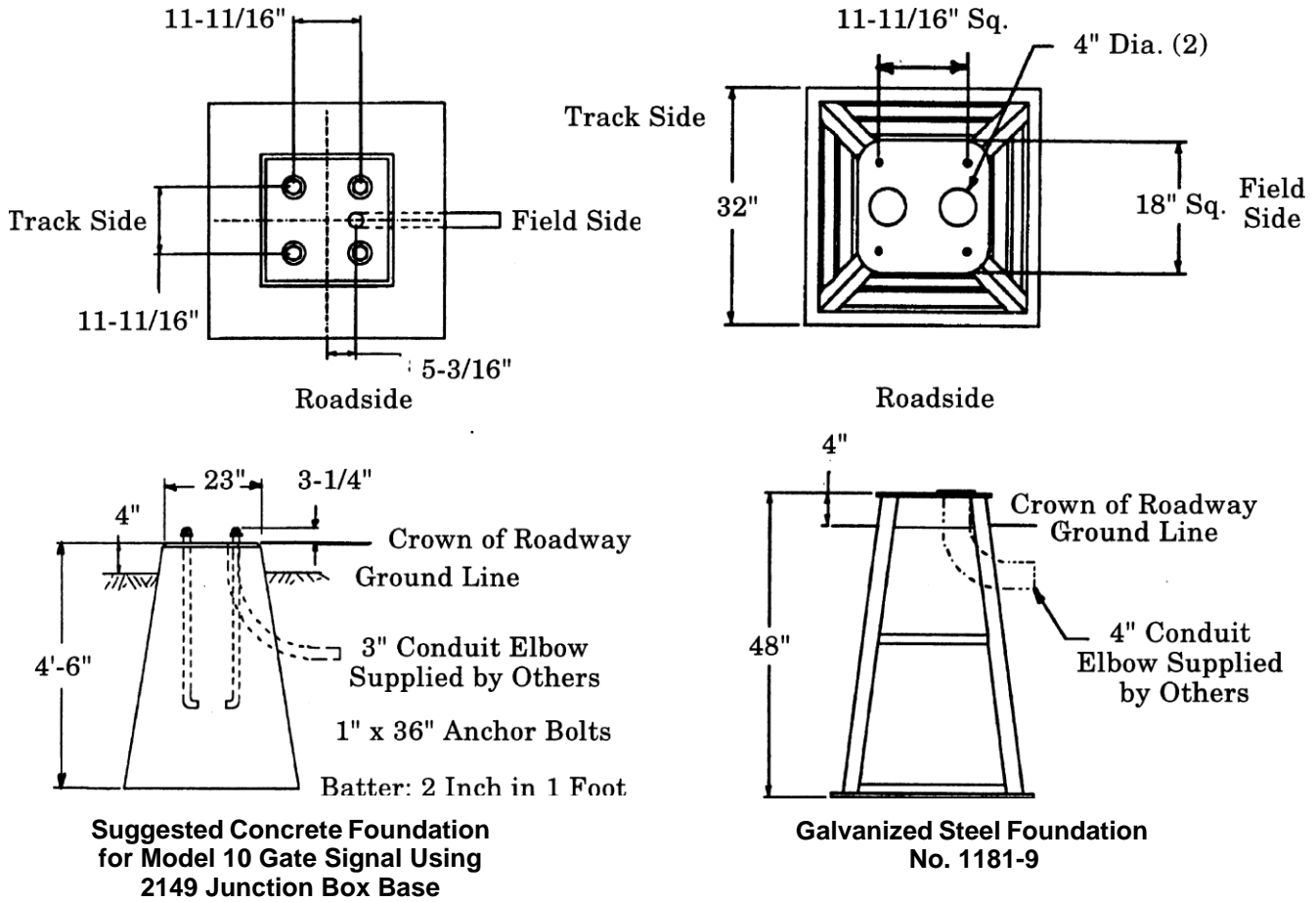

**Figure 1**

**Figure 2**

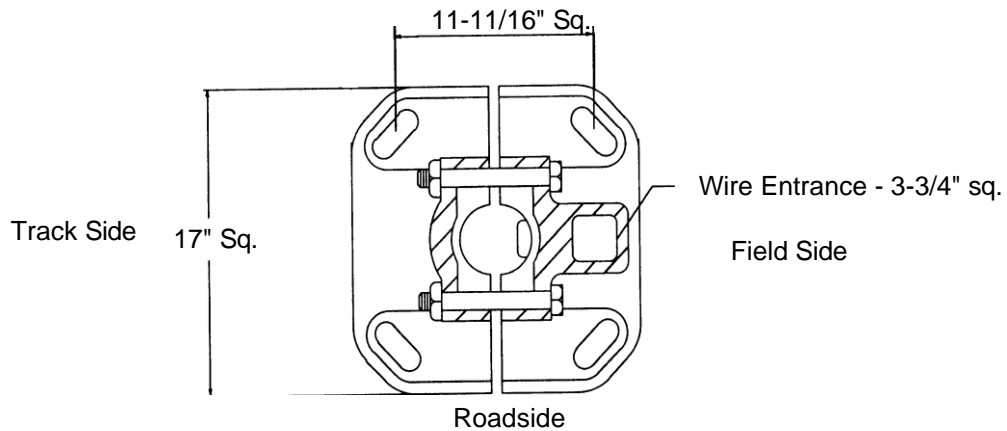
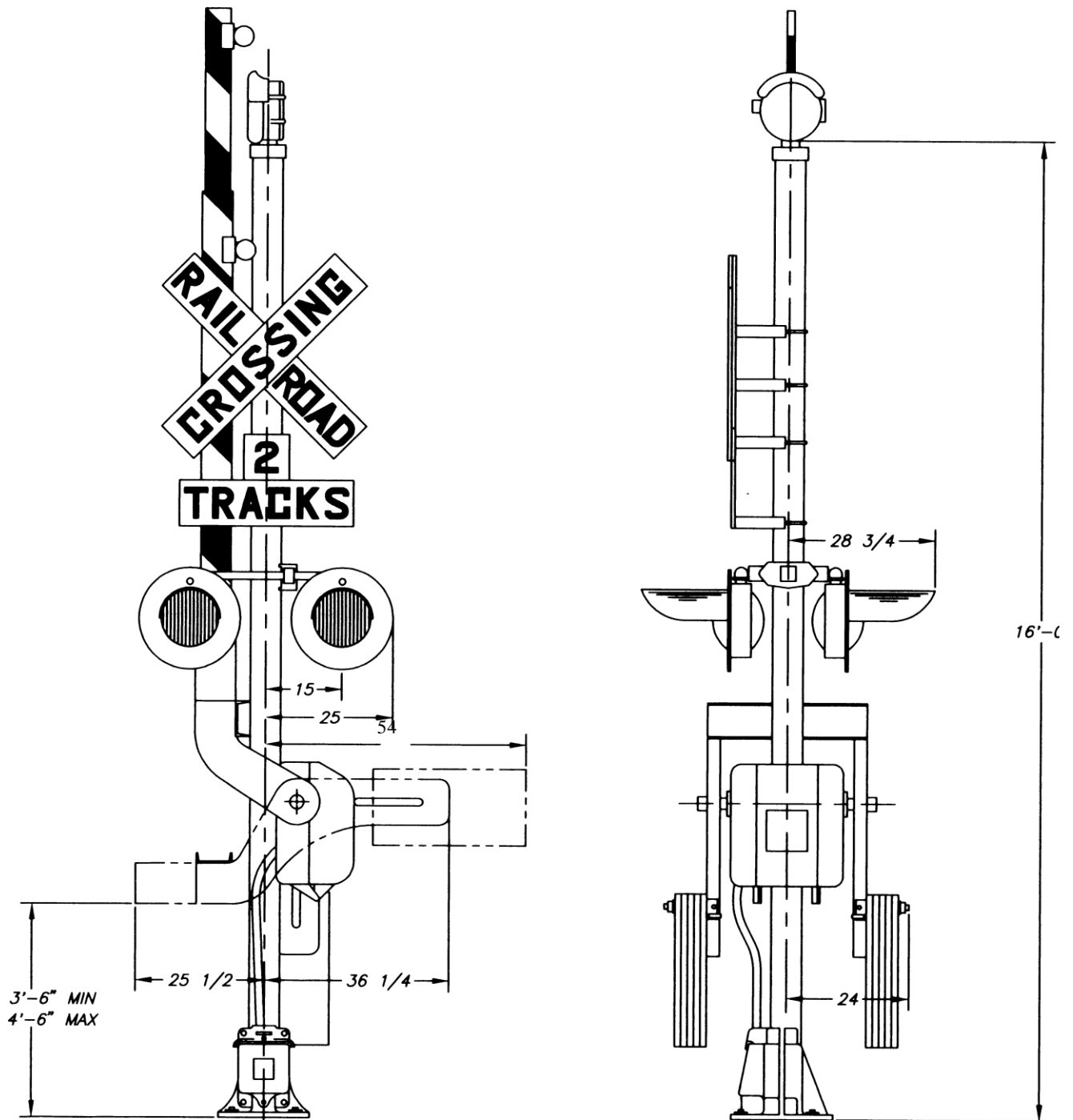

**Figure 2A**

- Remove the junction box cover to access the conduit adapter and hardware kit. Attach the conduit adapter to the top of the base. Loosen the base clamp bolts and install the lower pipe shield in the bottom of the base. Insert the signal mast into the base and tighten the base clamp bolts. Place the base and mast assembly on the foundation with the junction box cover facing oncoming traffic as shown in figure 3. Secure the assembly to the foundation anchoring bolts.

### Typical Model 10 Signal

Figure 3



3. Secure the mechanism support assembly to the mast 48 inches above the top of the foundation in a position as shown in figure 4. **Note:** Adjustment may be required to position the gate arm at 3'-6" to 4'-6" above of the Roadway Crown after the mechanism and gate arm are installed.
4. Install 4 square head bolts into the slots in the rear of the mechanism case. Set the mechanism onto the support assembly. Install saddle clamps and nuts.

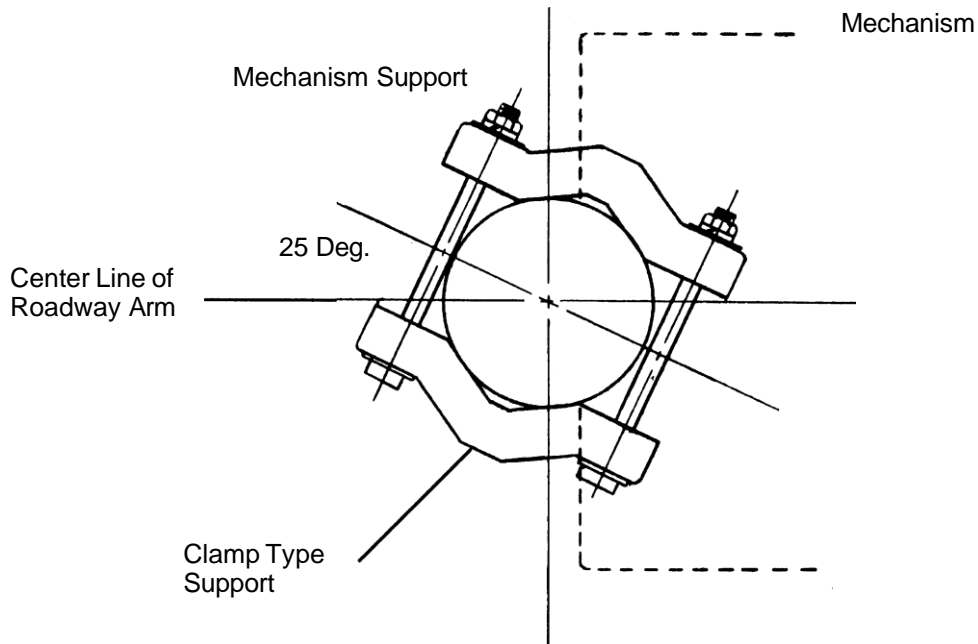

**Clamp Type Mechanism Support Installation**

**Figure 4**

5. Remove hole plugs from mechanism case. Install conduit fittings, adapters, cable grip and ventilator. Install the 1-1/2" sealtite from the base to the mechanism. Be sure enough slack is available to allow rotation of the mechanism.
6. Remove nuts, washers and spline protectors from the ends of the mechanism main shaft.
7. Make sure the main shaft is in the position it assumes when the gate arm is down (horizontal). This condition exists when segment gear (A) is resting on the horizontal stop pin (B) at point (C) as shown in figure 5.

Ref. No.	Description
A	Segment Gear
B	Horizontal Stop Pin
C	Contact Point
D	Horizontal Stop Spring Housing
E	Vertical Stop Pin
F	Vertical Stop Pin Nut
G	Clearance Gap 3/32" Minimum
H	Horizontal Stop Pin Locknut
J	Horizontal Stop Pin Cover
K	Verical Stop Pin Cover

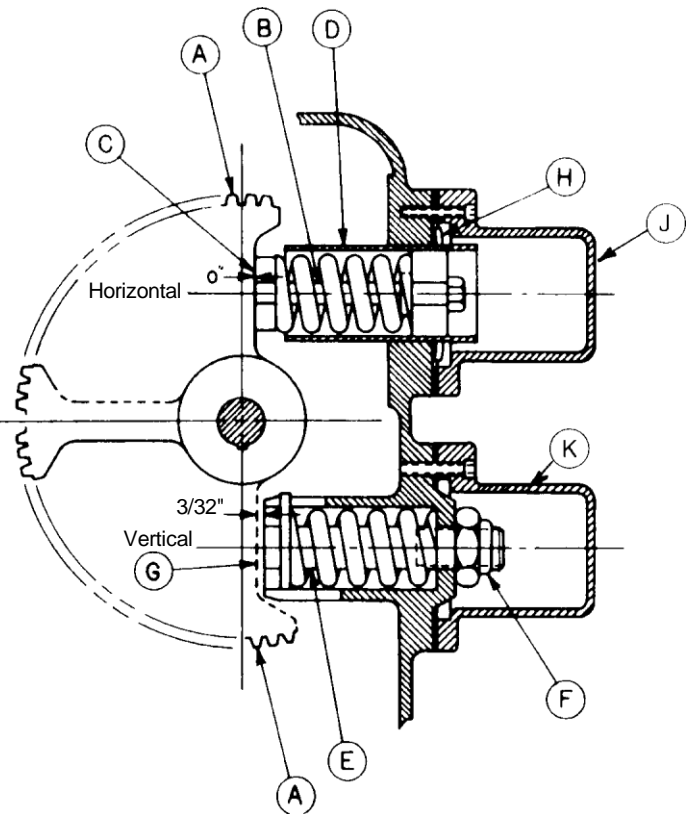

**Stop Detail**  
**Figure 5**

8. Refer to figure 6. If the mechanism is supplied with a sidewalk arm shaft (C), install the sidewalk arm adapter to the shaft at this time. Do not install the sidewalk arm. Apply gate arm counterweight support arms (B) to the mechanism main shaft (A). Keeping the gate end of the supports in the down (horizontal) position, install washers and hand tighten nuts on the main shaft.

**CAUTION: Do not apply counterweight before the roadway gate arm is installed.**

9. Install conversion bracket, breakaway adapter channel, or Gate Gard (D) to the counterweight support arms (B). Secure with provided hardware. The square head bolts fit into the recess on the support arm with the threads facing outward.
10. Tighten all installed hardware.
11. **Installation of fiberglass or aluminum/fiberglass gate arms**

Assemble the arm by sliding sections together to achieve desired length. In some cases, it may be necessary to drill holes in the inserted arm section. Secure sections with provided hardware.

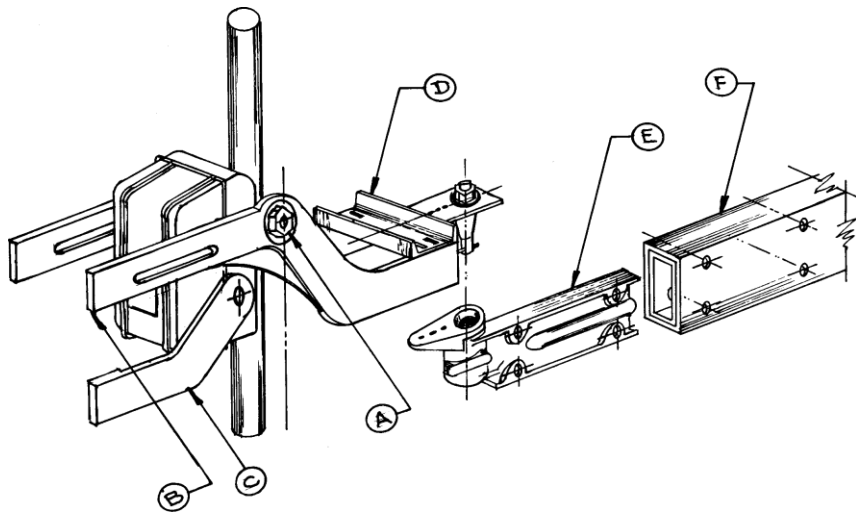

**Gate and Counterweight Support Installation**

**Figure 6**

Ref. No.	Description
A	Main Shaft
B	Gate and Counterweigh Support Arms
C	Sidewalk Arm Adapter
D	Conversion Bracket or Adapter
E	Cast Breakaway Adapter
F	Gate Arm Section



## PIVOT TYPE BREAKAWAY ADAPTER

Referring to figure 6, page 13, insert the cast breakaway adapter (E) into the gate arm end section (F) and secure with provided hardware. Position the gate arm with adapter attached 90 degrees from the mechanism assembly. Slip adapter onto mounting pin. Rotate arm 90 degrees, until the holes in the adapter align with the holes in the conversion bracket.

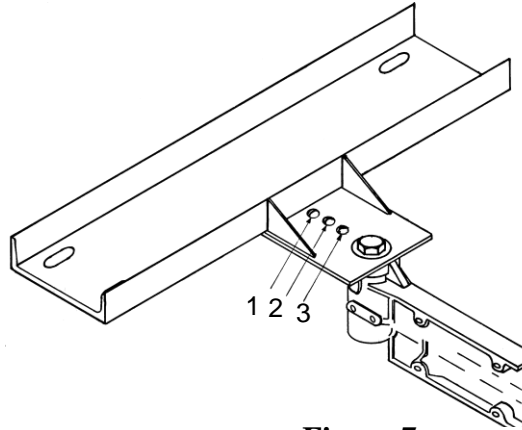

**Figure 7**

Install brass shear bolts in holes as instructed below. Gate arm length is measured from the centerline of the signal mast.

- 0-18' Gate Arms - Holes 2 and 3
- 19'-28' Gate Arms - Holes 1 and 2
- Over 29' Gate Arms - Holes 1, 2 and 3

## GATE GARD ADAPTER

Referring to figure 6, Page 13, install the Gate Gard (D) adapter onto the counterweight arms (B). Observe the instruction sheet provided with the Gate Gard. Install gate arm (F).

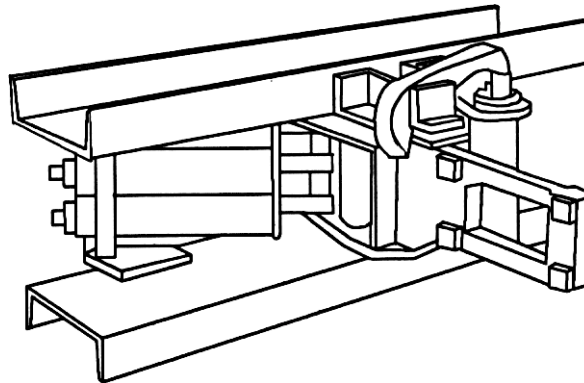

**Figure 7A**

12. Install gate arm lights using provided hardware. Attach cable to the arm using eyelets provided. Leave slack in the cable between eyelets to provide drip points. Route cable through cable grip installed in the mechanism and terminate wires at required binding posts or fuse block panel. Refer to figure 9 for proper lamp spacing.
13. Install signal light units, signs and bell or pinnacle as required. Complete electrical wiring to these units.

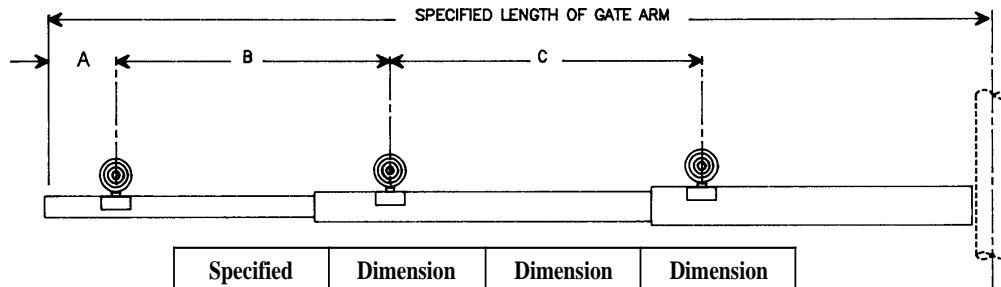

Specified length of gate arm	Dimension "A"	Dimension "B"	Dimension "C"
16-17 Ft.	24"	48"	48"
18-19 Ft.	28"	46"	46"
20-23 Ft.	28"	46"	46"
24-28 Ft.	28"	60"	60"
29-31 Ft.	36"	72"	72"
32-34 Ft.	36"	84"	84"
35-37 Ft.	36"	108"	108"
38 Ft. & Over	36"	120"	120"

**Suggested Roadway Gate Arm Light Spacing  
Figure 8**

**NOTE: The installation must be properly wired and power applied at this time, and from this time forward.**

14. **Installation of Counterweights**  
Oblong counterweights on cast iron or aluminum counterweight arms.  
Refer to figure 9, page 16 and tables 1 and 2, pages 21 and 22.

Install the counterweight support plate to the counterweight arm by inserting the clamp washer (short) studs through the slot from the outside of the arm. Install the clamp washers, flat washers and nuts to the studs. Locate the support plate near the center of the slot and tighten the clamp washer nuts. Be sure that the teeth in the clamp washers are seated into the teeth on the inside of the counterweight arm.

Raise and secure the gate arm in the up (vertical) position. Install the counterweights to the counterweight (long) studs. Install the flat washers and nuts to these studs and hand tighten the nuts. If two counterweight arms are supplied, distribute the weights evenly on the two arms. Align the weights and insert the alignment bolt into the holes at the bottom of the weights. Install washers and nut onto the alignment bolt and securely tighten. Now position the weights near the middle of the slot in the weights and securely tighten the counterweight nuts. Lower the gate arm to the horizontal position.

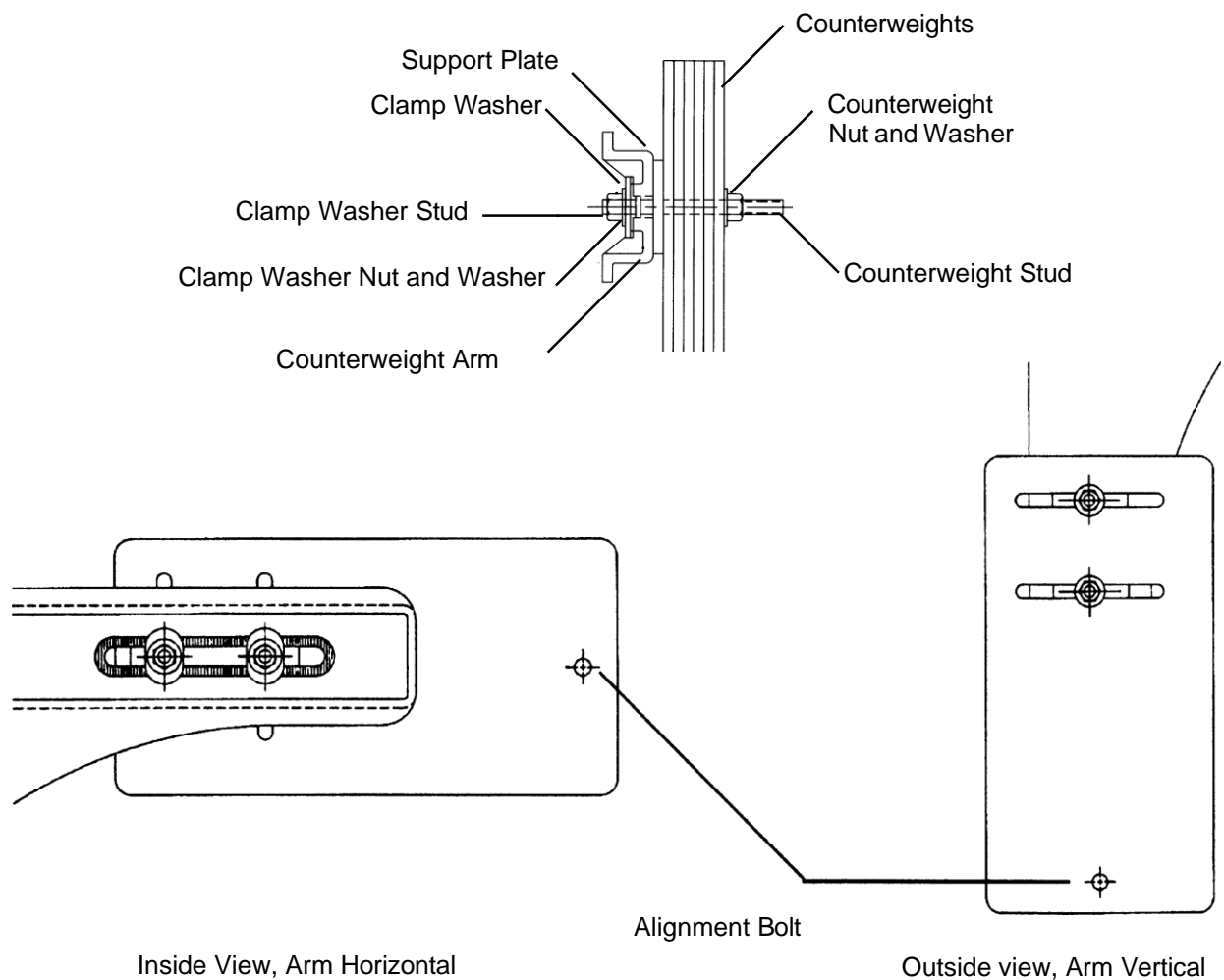

**Oblong Counterweight Assembly  
Figure 9**

15. **Horizontal Torque Adjustment**

Oblong counterweights on cast iron or aluminum counterweights arms.  
Refer to figure 10, page 18.

**NOTE: If a sidwalk arm is being used, all torque adjustments must be made with the sidwalk arm support installed and the  $\beta$  sidwalk gate arm installed.**

Open the mechanism cover and place the gate in the horizontal position by operating the cam switch, C, to the test position. Once the gate rests in the horizontal position, press the reset button on the EGM and be certain that the green LED is lit.

A. **Using torque wrench PN:3590-K9**

**NOTE: Do not attempt to obtain reading with a foot pound torque wrench placed on the mainshaft or by using other than the WCH torque wrench specified.**

Push down on the counterweights to raise the gate arm about 2 feet.

Attach the 7/8" socket attached to the torque wrench onto the hex surface on the motor pinion gear.

Slowly release the counterweight arm and allow the wrench to rotate and rest against the housing. Note the scale reading.

**The reading should be between 100 and 120 pounds regardless of the gate arm length.**

If adjustment is required, loosen the clamp washer nuts to allow the weights to be moved. If the reading is more than specified, move the counterweights away from the mechanism. If the reading is less than specified, move the counterweights toward the mechanism.

When weights are installed on two counterweight arms, move the weights on each arm proportionally.

After the proper scale reading is achieved, remove the torque wrench. Tighten the clamp washer nuts securely. Be sure the teeth on the clamp washers are securely seated into the teeth in the counterweight arm. Remove the Torque Wrench.

B. **Using spring scale PN: 3562-210**

Attach the 50 pound spring scale to the gate arm at a point located 10 feet from the center of the mechanism main shaft.

**Lift the gate by the scale and note the scale reading. The scale reading should be 10 to 12 pounds regardless of the length of the gate arm.**

If adjustment is required, loosen the clamp washer nuts to allow the weights to be moved. If the reading is more than specified, move the counterweights away from the mechanism. If the reading is less than specified, move the counterweights toward the mechanism.

When weights are installed on two counterweight arms, move the weights on each arm proportionally.

After the proper scale reading is achieved, remove the scale. Tighten the clamp washer nuts securely. Be sure the teeth on the clamp washers are securely seated into the teeth in the counterweight arm.

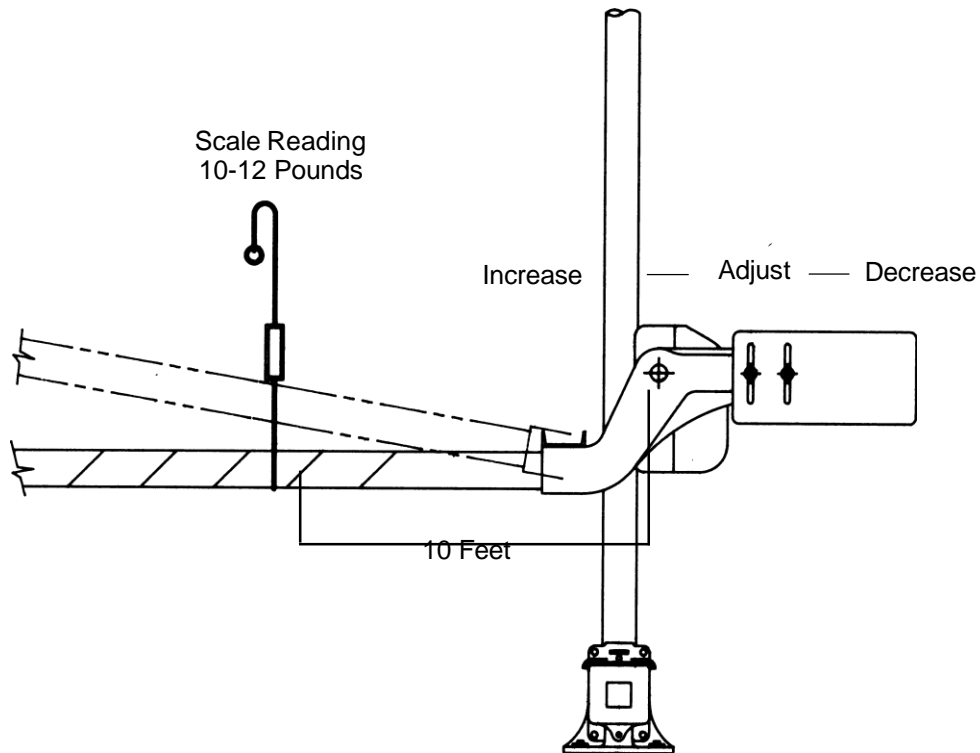

Horizontal Torque Adjustment  
Shown with Oblong Counterweights

Figure 10

16. **Vertical Torque Adjustment**

Refer to figure 11, page 20.

Control the gate to vertical position. Press the EGM Reset button, Operate the cam switch, to the run position.

A. **Using torque wrench PN: 3590-K9**

**NOTE: Do not attempt to obtain reading with a foot pound torque wrench placed on the mainshaft or by using other than the WCH torque wrench specified.**

Attach the 7/8" socket attached to the torque wrench onto the hex surface on the motor pinion. Securely hold the wrench with your right hand. Operate the cam switch to the test position with your left hand.

Rotate the torque wrench counterclockwise until it is near the mechanism case. With your left hand, hold in on the hold clear armature. While holding the armature, remove the torque wrench. Rotate the wrench clockwise, reinstall onto the motor pinion and grasp securely. Release the armature and once again rotate the wrench until it is near the mechanism case. Repeat this operation 6 times, then allow the wrench to rest on the mechanism case.

Observe the torque reading. Compare the reading with the torque specification for the applied length of gate arm as listed in tables 1 & 2, pages 21 and 22.

**If the reading is not within plus or minus 20 pounds of the specification, adjust the counterweights to achieve a reading within specifications.**

Loosen the counterweight stud nuts just enough to allow the weights to slide in the weight slots. If the reading is more than specified, move the counterweights away from the roadway. If the reading is less than specified, move the counterweights toward the roadway.

Repeat procedure as required until the scale reading is within the listed specification.

Hold in on the hold clear armature, remove wrench, operate the cam switch to the run position. If necessary, raise the gate by applying finger pressure on contact #2 to power the gate up.

When complete. Remove the torque wrench. Tighten the counterweight stud nuts.

#### **B. Using spring scale PN: 3562-210**

Refer to Figure 11, Page 20.

Control the gate to the vertical position.

Attach the 50 lb spring scale between the gate arm and the mast, on a horizontal plane, at "X" distance from the center of the mechanism main shaft. Refer to tables or pages, to determine "X" distance for the length of applied gate arm.

Place the cam switch in the test position and press the EGM reset button. The gate will lower and be restrained by the scale. Note the scale reading and compare with the specification in tables 1 or 2, pages 21 and 22 .

If adjustment is required, loosen the counterweight stud nuts just enough to allow the weights to slide in the weight slot. If the reading is more than specified, move the counterweights away from the roadway. If the reading is less than specified, move the counterweights toward the roadway.

Operate the cam switch to the run position. If necessary, raise the gate by applying finger pressure on contact #2 to power the gate up.

When complete, securely tighten the counterweight stud nuts.

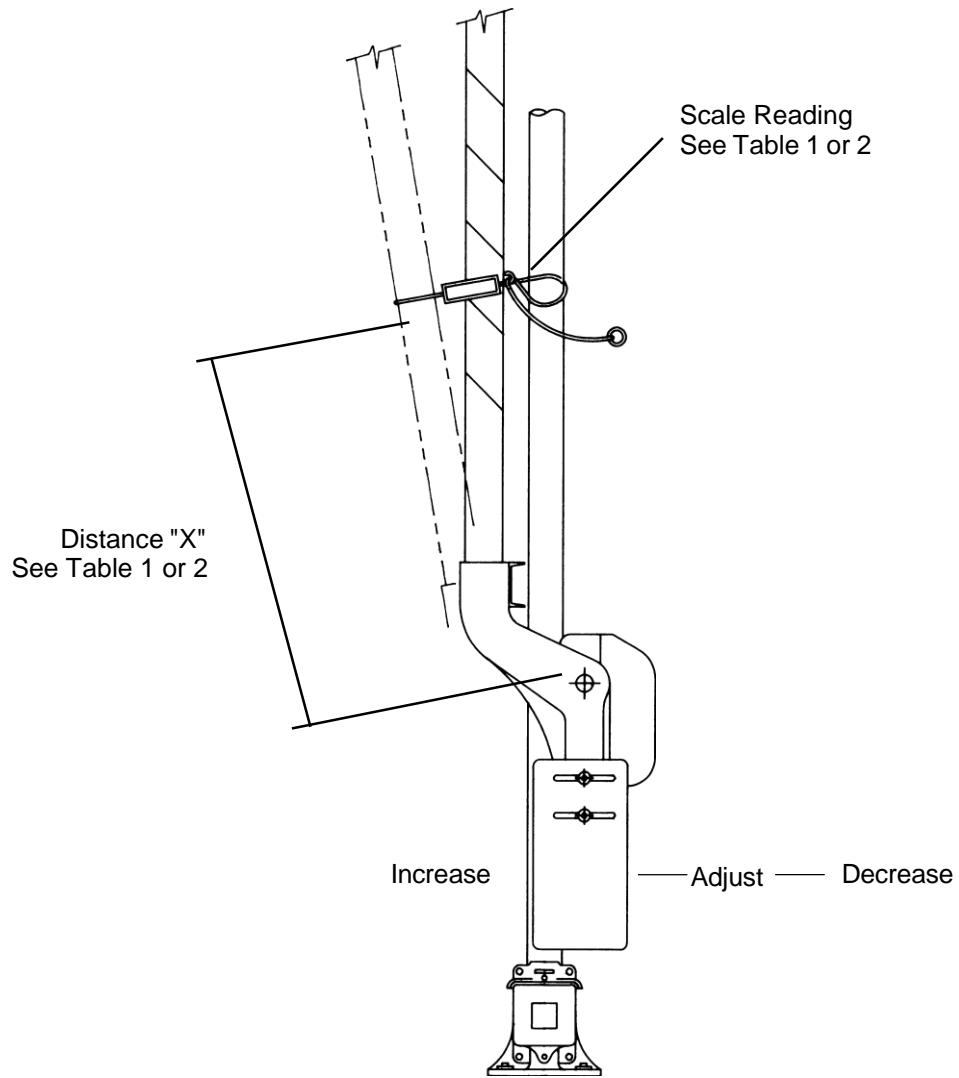

**Vertical Torque Adjustment  
Shown with Oblong Counterweights**

**Figure 11**

**Table 1**

TABLE OF WEIGHT AND VERTICAL TORQUE VALUES FOR  
FIBERGLASS AND ALUMINUM/FIBERGLASS GATE ARMS.

**OBLONG COUNTERWEIGHTS WITH CAST IRON COUNTERWEIGHT ARMS.**

Gate Arm Length in Feet	Counterweight Arms	Counterweight Supplied in Pounds	Counterweights Supplied 47lb.	Torque Wrench Reading (ft.lbs)	Spring Scale Reading (lbs)	Distance "X" in Feet
18	2	188	4	200	36	5
19	2	235	5	200	38	5
20	2	235	5	200	40	5
21	2	235	5	210	42	5
22	2	235	5	220	44	5
23	2	235	5	230	46	5
24	2	235	5	240	48	5
25	2	329	7	250	50	5
26	2	329	7	260	26	10
27	2	329	7	270	27	10
28	2	329	7	280	28	10
29	2	376	8	290	29	10
30	2	376	8	300	30	10
31	2	376	8	310	31	10
32	2	376	8	320	32	10
33	2	564	12	330	33	10
34	2	564	12	340	34	10
35	2	564	12	350	35	10
36	2	564	12	360	36	10
37	2	564	12	370	37	10
38	2	564	12	380	38	10
39	2	564	12	390	39	10
40	2	564	12	400	40	10



TABLE OF WEIGHT AND VERTICAL TORQUE VALUES FOR  
FIBERGLASS AND ALUMINUM/FIBERGLASS GATE ARMS

**OBLONG COUNTERWEIGHTS WITH ALUMINUM COUNTERWEIGHT ARMS**

Gate Arm Length in Feet	Counterweight Arms	Counterweight Supplied in Pounds	Counterweights Supplied 47lbs.	Torque Wrench Reading (ft.lbs.)	Spring Scale Reading (lbs.)	Distance "X" in Feet
1 8	2	235	5	200	3 6	5
1 9	2	282	6	200	3 8	5
2 0	2	282	6	200	4 0	5
2 1	2	282	6	210	4 2	5
2 2	2	282	6	220	4 4	5
2 3	2	282	6	230	4 6	5
2 4	2	282	6	240	4 8	5
2 5	2	376	8	250	5 0	5
2 6	2	376	8	260	2 6	1 0
2 7	2	376	8	270	2 7	1 0
2 8	2	376	8	280	2 8	1 0
2 9	2	423	9	290	2 9	1 0
3 0	2	423	9	300	3 0	1 0
3 1	2	423	9	310	3 1	1 0
3 2	2	423	9	320	3 2	1 0
3 3	2	611	13	330	3 3	1 0
3 4	2	611	13	340	3 4	1 0
3 5	2	611	13	350	3 5	1 0
3 6	2	611	13	360	3 6	1 0
3 7	2	611	13	370	3 7	1 0
3 8	2	611	13	380	3 8	1 0
3 9	2	611	13	390	3 9	1 0
4 0	2	611	13	400	4 0	1 0

## SECTION 3 INTERNAL ADJUSTMENTS

### 1. Gate Descending Time

After the counterweights have been adjusted, check gate descending time. The gate should descend between 10 and 15 seconds from the time the gate down command is given to the time the gate is horizontal. This speed is adjusted with the snub resistor and the #7 snub cam. The snub resistor is the top resistor located on the relay panel above the shorting resistor.

Using the control in the crossing control case, raise the gate. Do not use the mechanism cam switch during this adjustment. Command the gate to lower and record the time. If the gate needs to descend faster, move the resistor slide to the right. If the gate needs to descend slower, move the resistor slide to the left.

The #7 snub cam is factory set at 2 degrees. If the horizontal stop is adjusted, check the position of the snub cam. If increased gate arm snubbing on a longer gate arm is required, adjust the snub cam to close the contact sooner (5 to 10 degrees). If you find that a short gate arm descends too slowly when the snub contact is closed, adjust the cam to reduce the snub, or remove the snub altogether.

When complete, adjust the mechanism shorting resistor. This resistor is the bottom resistor located below the snub resistor.

Raise the gate. Operate the mechanism cam switch to the test position. The gate will begin to descend rapidly. The EGM will trip and apply the shorting circuit. If the gate needs to descend faster, move the resistor slide to the right. If the gate needs to descend slower, move the resistor slide to the left.

It is recommended the gate descend speed operating under this condition be similar to the gate descend speed under normal conditions. The gate should descend between 11 and 15 seconds from the time the mechanism cam switch is placed in the test position to the time the gate is horizontal.

Press the EGM reset button and place the cam switch in the run position. The gate will raise to the vertical position.

### 2. Horizontal Gate Position Adjustment

The gate horizontal position would place the gate parallel to the crown of the roadway and between 3'-6" to 4'-6" above the crown of the roadway. If is necessary to adjust the gate horizontal stop, follow these procedures while referring to figure 5, page 12.

- a. Lower the gate. The segment gear (A) should be resting on the stop pin (B) at point (C).
- b. Remove the stop pin cover (J). Loosen the stop pin locknut. Rotate the stop pin assembly in or out until the arm is in the proper position.
- c. Tighten the locknut and replace the cover.

- d. By moving the stop, the snub contact adjustment will have been altered. Be certain to check the snub cam position during the setup process.
- e. Tighten the stop pin locknut and reinstall the cover.

### 3. **Contact Cam General Information.**

Refer to figures 16A and 16B, page 27.

Cams and contacts are factory set at the positions shown on the wiring diagram, plus or minus 2 degrees. This setting is considered a starting point as some cams will be adjusted during installation. An angle finder PN: 3590-1014, is available to check cam operating positions.

Be sure that the slots in the power up cam (G) are kept free of foreign material at all times and that cam and cam follower surfaces are clean.

There are three different cams in the 3597 mechanism. Cam #1 is a fixed high rise cam PN: 38-0045-536, cam #2 is a sliding cam PN: 38-0045-92, and the remaining cams are standard fixed cams, PN: 38-0045-55. When replacing a cam, be certain that the proper cam is used in the proper position.

When adjusting or replacing any cam, care should be taken when tightening the cap screw. Referring to figure 16B. The motor up cam has a slotted insert (G), which allows for radial travel. When cam insert (H) is rotated to the closest point toward cap screw (L), a minimum gap of 1/16 inch must be maintained between the cap screw and the cam insert at location (J).

Referring to figure 16A, for all fixed cams a minimum gap of 1/16 inch must be maintained between cam insert (E) and cap screw (A) at position (K).

The #7 snub cam is factory set at 2 degrees. If the horizontal stop was adjusted, check the position of the snub cam. If increased gate arm snubbing on longer gate arms is required, adjust the snub cam to close the contact sooner (5 to 10 degrees). If you find that a short gate arm descends to slowly when the snub contact is closed, adjust the cam to reduce the snub, or remove the snub altogether.

Contact #3, 5 and 6 are for customer use and there are no other specific instructions. Contact #4 is for customer use to indicate a gate clear condition. Specific instructions for this cam are given in paragraph 4 of this section. Specific instructions for cams #1, 2 and 4 are also given in paragraph 4. Instructions for cam #7 are given in paragraph 1 and paragraph 3.

#### 4. Vertical Gate Position. Contact Cam Adjustments and Vertical Stop Adjustment.

If your requirements are such that the gate vertical position will have to be adjusted, please follow the following procedures:

- a. Place the gate in the horizontal position. Attach the angle finder to the main shaft and position to read zero.
- b. Raise the gate to vertical. Loosen the #2 motor up cam cap screw and adjust the cam as required. Be certain that the sliding position of the cam is fully downward within the cam frame. Tighten the cap screw.
- c. Cycle the gate and check vertical position. When all adjustments are complete, the ramp of the cam should sit approximately 1/16-1/8 inch from the cam follower when the gate is in the vertical position.
- d. Check the vertical stop pin clearance. Check this with a 3/32 inch wire gauge, PN: 3590-1013. This is the minimum clearance between the segment gear and the vertical stop pin. There is not a maximum specification. **DO NOT PLACE HANDS INTO THE GEAR AREA WHEN CHECKING THIS CLEARANCE.** If the angle finder reading is less than 84 degrees, do not adjust the vertical stop pin.
- e. If vertical stop pin adjustment is required, refer to figure 5, page 12. Remove the stop pin cover (K). Turn the stop pin nut (F) as required to obtain the minimum 3/32 inch clearance between the segment gear (A) and stop pin (E) point (G).
- f. Recheck vertical position. If the #2 power up cam was adjusted, check the position of the gate clear contact cam #4. Adjust the cam so that the cam follower is resting completely on the end of the cam surface, not on the ramp, when the gate is in the vertical position.
- g. Depending on the final gate vertical position, it may be necessary to adjust the #1 gate down cam. The final position of the #1 cam would have the cam follower between 1/8" to 3/16" from the end of the ramp of the cam when the gate is in the vertical position, regardless of the angle finder reading. This specified gap must be maintained to allow proper gate down operation.

#### 5. Circuit Controller Contact Adjustment

**Contact Tension is listed on the wiring diagram and should be periodically checked.**

To adjust a contact, it will be necessary to bend the contact spring to achieve the following specifications by using the contact adjusting tool, PN: ES-6104-2, an ounce spring scale, PN: 3565-211 and a 1/16 inch insulated gauge PN: 3590-1010.

When adjusting contacts, gently bend the contact spring by applying several gentle upward or downward forces against the contact spring. Recheck the gap or pressure after each operation. Repeat this procedure until specification is achieved. Overbending may damage the contact and make it impossible to achieve proper contact spring pressure. Always apply the adjusting tool at the top of the contact directly beneath the circuit controller board. Never bend the contact body or at the bend near the contacting surface. Do not twist the contact while bending. Minimum contacting area must be 1/4 inch.

- a. To adjust contacts 2 thru 7 follow these procedures. Inspect and adjust any contact that appears to have 1/8 inch or greater gap. Refer to figure 16A. Using a 1/16" insulated gage, PN: 3590-1010:
  1. With the contact in the fully open position, the clearance between the cam follower (B) and the metal frame of the cam (C) must be a minimum of 1/16 inch. To adjust, bend the back or heel contact until specification is achieved.
  2. With the contact in the fully open position, the clearance between the contacting surfaces (D and F) must be a minimum of 1/16 inch. To adjust, bend the front contact until specification is achieved.

Using an ounce spring scale, PN: 3565-211, and contact adjusting tool, PN: ES-6104-2, adjust contact spring pressure as follows. Refer to figure 16A and specification items (D) and (F).

Position the gate so that the contact cam follower (B), is well upon the cam surface (E) or (H) and the contact is fully closed. Hook the end of the scale to the front contact at the bend (F), near the contacting surface and lift gently until the contact opens. To adjust, bend the front contact while the contact is closed. To reduce pressure, bend the contact away from the cam. To increase pressure, bend the contact toward the cam.

- b. There is a front and back contact at position #1. The back contact powers the gate down while the front contact snubs the gate down. Refer to figure 16A. The gap specification for these contacts is a minimum of 1/8 inch. Inspect and adjust if gap appears to be greater than 3/16 inch. Use a 1/8" insulated gage, PN: 3590-1015 for this check and adjustment.

To adjust the front contact, follow the proceeding procedure. The only difference is that the contact gap specification is minimum of 1/8 inch. The back contact gap is also a minimum of 1/8 inch. To adjust the back contact, use a 1/8" insulated gauge, PN: 3590-1015 and follow these procedures:

1. To check and adjust the back contact, lower the gate to the horizontal position. Check the gap (D) using a 1/8 inch or 2, 1/16 inch insulated gauges.
2. Raise the gate. Attach the scale to the #1 heel contact at a position just below the cam follower (B) and lift gently until the contact just opens. **BE CAREFUL NOT TO SHORT THE CONTACTS WITH THE SCALE.**
3. To adjust the gap or tension, adjust the back contact (M) using PN: ES-6104-1 contact bending tool for contacts with stiffeners. Always bend the contact while it is closed. To reduce pressure, bend the contact toward the cam. To increase pressure, bend the contact away from the cam.

**CAUTION: Do not overbend the contact. Overbending may damage the contact and make it impossible to achieve the correct gap or contact spring pressure.**

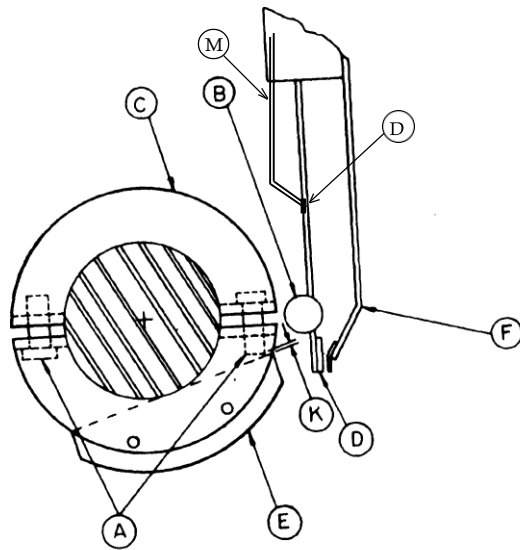

**Cam and Contact Detail**

**Figure 16 A**

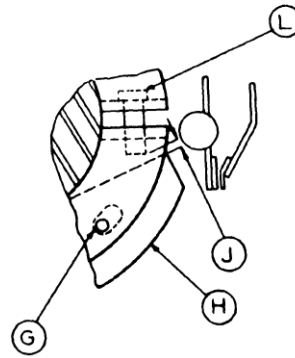

**Sliding Cam Detail**

**Figure 16 B**

Contact Tension: #1, 2 = 18 to 28 oz.  
 All others = 16 to 24 oz.

Ref. No.	Description
A	Cap Screw
B	Cam Follower
C	Cam Frame
D	1F and 1B minimum gap 1/8" All others minimum gap 1/16"
E	Cam Insert Surface
F	Attached Spring Scale

Ref. No.	Description
G	Cam Slot
H	Cam Insert Surface
J	Minimum Gap 1/16"
K	Minimum Gap 1/16"
L	Cap Screw
M	Back Contact

## 6. Hold Clear Device

The armature support assembly should have appreciable end play on its pivot and should not be restricted in any manner by friction or any tendency to bind.

Refer to figures 18, 19 and 20, pages 38, 39 and 41.

The parallelism between the hold-clear armature, (10, figure 19, page 39), and its pole pieces, (15, figure 19, page 44), at time of latching is controlled by set screw and attendant lock nut. The lock nut should be kept tight to prevent movement of the set screw. If field adjustment is required, this measurement should be undertaken when the hold-clear device is de-energized. Hold in on the armature. Adjust the set screw to achieve a gap of .064" between the armature plate and the pole faces. **DO NOT TAKE THIS MEASUREMENT ON THE AMATURE RIVETS.**

When complete, tighten the set screw lock nuts. If the parallelism adjustment is changed, it will be necessary to readjust the pawl to ratchet clearance and the stop springs per the following instructions.

The armature support bracket springs, (6, figure 19, page 39), are adjusted as follows; with the hold-clear coil energized and the armature held against the pole faces, the nuts are tightened until the coils of the springs are compressed together lightly, then each nut is backed off one-half turn and locked in place with the cotter pin.

Engagement between the ratchet wheel, (1, figure 18, page 38), and the pawl, (2, figure 19, page 39), is controlled by the position of the hold-clear device on the motor face. With the hold clear coils energized and the armature, (10, figure 19, page 39), against the pole faces, the tip of the pawl should **just touch** the bottom or root of the space between the ratchet wheel teeth. This adjustment is set at the factory. If field adjustment becomes necessary, loosen the three hex head cap screws holding the hold-clear to the motor and move the entire hold-clear assembly to the proper position. Retighten the mounting screws. If this adjustment is changed, check the ratchet teeth to pawl clearance.

In the de-energized position, the pawl should clear the ratchet wheel teeth by a minimum of .020 inch. This clearance is controlled by stop screw and attendant lock nut (12, figure 19, page 39). This adjustment should be maintained in service and the lock nut kept tight to prevent movement of the stop screw. If this adjustment is changed, recheck the ratchet wheel to pawl engagement.

The pawl is double-sided. When the tip becomes worn to the point where it will not properly engage the ratchet wheel, it may be taken off the hold-clear device, turned around and reattached. When both tips are worn, the pawl and pawl screw should be replaced.

A blocking diode is located on the hold clear block which is connected to the PF side of the pick coil. Refer to wiring diagram 3597-WD-E. If the pick coil fails to energize, check the condition of this diode before testing the coil itself. If diode replacement is ever necessary, be certain to install the diode in the direction indicated on the wiring diagram. The mechanism should never be left in service with this diode removed or jumped. Refer to figure 20, page 41.

## 7. Motor Down Contact Adjustment on Hold Clear 38-0045-510

Refer to figure 20, page 41.

Disconnect one contact wire from the terminal block (10). Apply hand pressure to the armature plate, (10, figure 19, page 39), to hold the armature in the closed, (energized) position. Check the gap between the contacts (8 and 9). The gap should be set at 0.032 inch. Check with gauge, PN: 3590-1011. To adjust the gap, remove the contact shield. Insert contact adjusting tool, PN: ES-6104-2 onto the lower contact (9), near the mounting block spacer (4). To increase the gap, apply several forward forces on the tool to bend the contact. To decrease the gap, apply several rearward forces to bend the contact.

Release the armature. Check the contact spring pressure. Place the straight end of the ounce spring scale, PN: 3565-211, on the upper side of the lower contact (9) near the bend in the contact. Press downward on the contact until the contact just opens. The reading should be no less than 4 ounces. If it is necessary to adjust the contact spring pressure, remove contact shield, insert contact adjusting tool, PN: ES-6104-2 onto the lower contact (9), near the mounting block (4). With a finger on the top of the upper contact (8), securely hold the contacts against the contact operating cam, (8, figure 19, page 39). To increase the pressure, apply several rearward forces on the tool to bend the contact. To decrease the pressure, apply several forward forces to bend the contact.

**CAUTION: Do not overbend the contact. Overbending may damage the contact and make it impossible to achieve the correct gap or contact spring pressure.**

## 8. Ratchet Wheel

Refer to figure 18, page 38.

The ratchet wheel includes a press-fit, pre-lubricated and shielded one-way clutch. No maintenance of this unit is required. When the ratchet wheel becomes worn so as to interfere with proper latching or if the internal clutch becomes inoperative, it should be replaced.

A snap ring, (5) and key (2) hold the ratchet wheel in place on the motor shaft. If the ratchet wheel is removed for any reason, the snap ring should be replaced. When remounting the snap ring, care should be taken to insure that the rounded edges of the snap ring face into the ratchet wheel, thereby reducing the wear of the ratchet wheel cover plate. A light coat of multi-purpose oil should be maintained between the two parts to reduce wear.



## SECTION 4 GENERAL MAINTENANCE

### 1. Service and Tests.

All mechanisms are given a final inspection and are properly lubricated and adjusted before shipment from the factory. Following is a list of setup and general checks.

- a. Inspection should be made to ensure that there is no oil, grease or dirt on the armature or pole faces of the hold-clear magnet. These surfaces should be kept clean at all times.
- b. Supply voltage should be maintained between 11 and 16 volts dc. Observing polarity, check supply voltage at the motor supply terminal points.
- c. Operate the mechanism through an up-down cycle and note operating voltage readings. As the gate goes up, voltage should not drop below 11 volts and current should range from 6 to 20 amps. As the gate descends, voltage should not drop below 11 volts and current should range from 6 to 15 amps. Readings will vary depending on the length of gate arm. If voltage drops below 11 volts during normal operation, check motor supply wiring between the battery and the mechanism terminal points for proper wire sizing and voltage drop. Correct wiring where necessary. Refer to wiring specifications in section 1.
- d. Perform a gate down test. Place the cam switch in the test position. The gate will begin to drop, then the EGM will trip thus slowing the gate considerably. When the EGM trips, the green LED will go dark. The gate then descends slowly to the horizontal position. When complete, press the EGM reset button and place the cam switch in the run position. The gate should rise to vertical.
- e. Lower the gates via the crossing controls, check descending speed. Normal field descending time should be between 10 and 15 seconds depending on gate arm length and local requirements. Long gate arms should usually operate slower than shorter arms. Arms of unequal length at the crossing should be adjusted to descend at near equal times. If adjustment is required, refer to section 3.1, gate descending speed.
- f. Check the clearing time. Depending on gate arm length and voltage supplied, the arm should raise to the clear position between 6 to 10 seconds. The speed of the gate is directly proportional to the voltage supplied.
- g. Check for grounds in the battery and control circuit wiring.
- h. Check the hold-clear release voltage as required by your railroad testing procedures and intervals. The hold-clear should release at not less than 2.5 volts dc, and the hold-clear should energize between 7.5 and 10 volts dc. Replace or repair any hold-clear that does not energize by 10 volts.

- i. No field adjustments are recommended to the motor control relay.  
Field tests suggested are:
1. Verify pick and drop values as required by your railroad testing procedures and intervals.  
The specifications for the P&B, PM Series Relay are:  
Coil Resistance: 32.3 ohm  
Nominal pick: 6.54  
Nominal drop: .72  
Replace any PM relay that fails to pick by 9 vdc.  
The specifications for the P&B, VF4 Series Relay are:  
Voltage: 6vdc  
Coil Resistance: 22.5 ohm +/- 10%  
Nominal Pick: 3.6  
Nominal Drop: 0.6  
Replace any relay that fails to pick by 4 vdc, double these values when testing the 2 relays in series.
  2. Visually inspect contacts for arcing or burning on a PM series relay.
- j. Perform a gate obstruction test. Place a DC voltmeter onto the power supply terminals. Place the gate in the horizontal position with the crossing controls. While a person holds the gate down, command the gate to rise. Check to be sure that voltage does not drop below 9 volts. After a time delay of not more than 45 seconds, the EGM should trip and release from the motor. The gate should be then held in place by the hold clear. If voltage drops below specification and the EGM does not release motor power, refer to the wiring requirements located in section 1.

**NOTE: The mechanism should be placed in service even if excessive voltage drop causes a failure of this test. This test is performed to determine if this feature is available. The anti pumping feature and gate arm knock off feature will still function which are more common occurrences than obstruction. It is the customer's decision if this feature is needed when existing wiring does not allow to be enabled.**

- k. If a total failure of the EGM unit occurs, follow this procedure to allow the gate to operate until a replacement unit can be installed. While wired in this manner the 3597 will operate as any normal gate mechanism. The EGM features will not operate. At the EGM unit:
1. Remove wire SHR2 from the EGM wire stud.
  2. Remove wire C5 from the EGM wire stud and connect it to EGM wire and stud MB.
  3. Leave all other EGM wiring in place.

**WARNING: Do not operate the cam switch to the test position if the EGM has been temporarily wired in this state; the gate arm will descend rapidly and damage can occur. Install a replacement EGM as soon as possible.**

1. The potentiometer of the EGM is factory set to trip at a minimum of 19 VDC. Field adjustment should not be required. To field test the EGM trip voltage, raise the gate and:
  1. Attached a recording DC voltmeter to the motor terminals.
  2. Place the cam switch in the test position. Observe the peak voltage on the meter as the gate lowers.
  3. If the reading is above 20 volts, the test is complete. Press the EGM reset button and place the cam switch in the run position to raise the gate.
  4. If the voltage is less than 20 volts, adjust the potentiometer clockwise one turn. Repeat this test and adjustment until a reading of 20 to 21 volts is achieved.
  5. Press the EGM reset button and place the cam switch in the run position to raise the gate.

**Please contact Western-Cullen-Hayes at 773-254-9600 if you have any questions or need assistance with any aspect of the 3597 Gate Mechanism.**

- m. EGM LED Modes:

The red and green LED indicators must be lit for proper mechanism operation. If red LED lit and green LED not lit, press reset button on left side of the EGM.

  1. The red LED indicates power is present at the EGM.
  2. The green LED indicates that the EGM relays are energized.
- n. To lower the gate counterweight assembly (raise weights) without a gate arm attached:
  1. Attach a 7/8" socket to a 1/2" drive ratchet wrench. Select the off position on the ratchet so that the ratchet free wheels counter-clockwise. Insert the socket onto the motor pinion gear hex surface.
  2. Securely grasp the ratchet wrench handle with your right hand.
  3. Operate and hold the cam switch to the down position with your left hand. The weights will rise and the ratchet wrench will free wheel.
  4. Once the weights have risen to horizontal position, release the cam switch knob. The knob will spring return to the test position. Observe when the segment gear is near the horizontal stop. Do not over-drive the mechanism against the stop.
  5. Carefully rotate the ratchet wrench clockwise until it rests on the upper cluster gear pin. Release the wrench. Four holes are provided in the lower cluster gear to insert a pin into to provide additional holding capability.
  6. When the gate arm has been attached, the weight of the arm will rotate the gears and the ratchet wrench will fall away from the gear pin. Remove ratchet wrench.
  7. Once the gate arm has been secured, operate the cam switch to the run position and press the reset button on the EGM. If a gate up command is present and the green LED is lit, the gate will clear.

# SETUP CHECKLIST

Location: \_\_\_\_\_

In Service Date: \_\_\_\_\_

1. Hold clear armature and pole faces clean. \_\_\_\_\_
2. Supply voltage between 12 and 16 volts DC. \_\_\_\_\_ volts
3. Voltage during gate up cycle. \_\_\_\_\_ volts
4. Amperage during gate up cycle. \_\_\_\_\_ amps
5. Gate down/EGM test. \_\_\_\_\_
6. Check and adjust descending time. Resistor screws tight. \_\_\_\_\_ seconds  
Check and adjust EGM test descending time. \_\_\_\_\_ seconds
7. Check clearing time. \_\_\_\_\_ seconds
8. Check for grounds in wiring. \_\_\_\_\_
9. Obstruction test Pass \_\_\_\_\_ Fail \_\_\_\_\_
10. Set horizontal gate arm torque. \_\_\_\_\_ ft. lbs.
11. Set vertical gate arm torque. \_\_\_\_\_ ft. lbs.
12. Gate parallel to roadway surface. \_\_\_\_\_
13. 3/32" clearance between segment gear and vertical stop. \_\_\_\_\_
14. Contact cams adjusted as specified in Section 3.

Installed by: \_\_\_\_\_

Checked by: \_\_\_\_\_

## 2. Lubrication.

Time interval for periodic lubrication will be governed by usage.

The mechanism gear train, main shaft and motor bearings are pre-lubricated and sealed. No periodic lubrication is required for these bearings.

The gear teeth are to be lubricated periodically with, PN: 3590-1733, Aeroshell 33 lubricating grease.

## 3. Motor Service.

Refer to figure 18, page 38.

The motor has a totally enclosed, non-ventilated housing and has pre-lubricated sealed bearings.

The motor brushes should be periodically inspected for wear. Replace brushes (11 and 12) when carbon portion has worn to 5/8 inch length or less.

**NOTE: Motor brush caps (13) screw on. Remove caps by turning counterclockwise. Hand tighten only when replacing caps. Always remove motor brushes (11) when gate arm is in the horizontal position. No dynamic braking is provided with a brush removed. Always replace brushes EXACTLY in the position they were in.**

## SECTION 5 OPTIONAL EQUIPMENT

1. Sidewalk Arm Kit permits the addition of a sidewalk arm to the mechanism in service as operator of roadway arm. The kit includes necessary bearings, gears, keys, shafts and instructions. It does not include a sidewalk arm bracket or a sidewalk arm (figure 23, page 44).
2. A heater may be attached to the mechanism for prevention of frost formation on controller contacts (figure 24, page 45).
3. Gate lamp fuse panel PN: 38-0045-540 (Figure 25, page 46).
4. Setup and adjustment tools are listed on the last page of the mechanism parts section.

**SECTION 6**  
**3597 CROSSING GATE MECHANISM**  
**REPLACEMENT PARTS**  
**Figure 17**

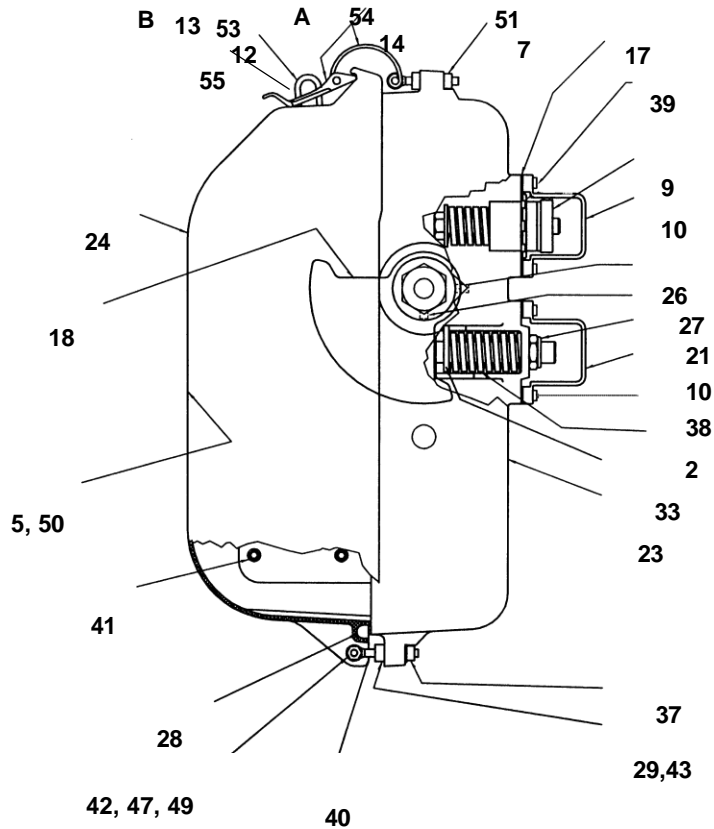
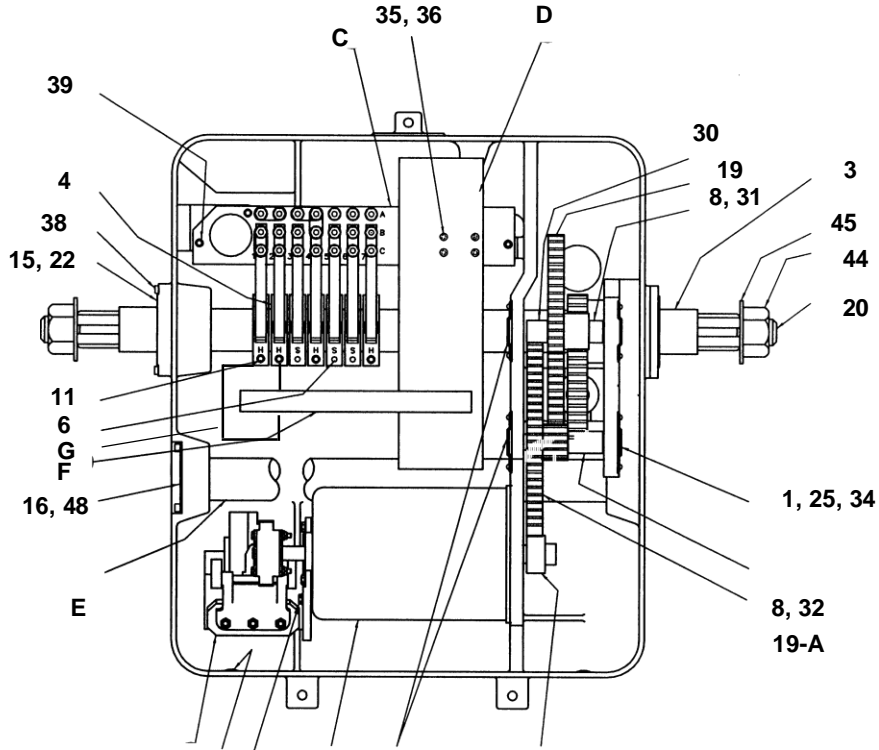

**3597 CROSSING GATE MECHANISM  
REPLACEMENT PARTS  
Refer to Figure 17**

<b>Ref. No.</b>	<b>Description</b>	<b>Part No.</b>
1	Bearing Cover	38-0045-30
2	Spring, Vertical Stop	38-0045-38
3	Spacer Tube	38-0045-42
4	Cam Assembly	38-0045-55
5	Wiring Diagram	3597-WD-E
6	Slide Cam Assembly	38-0045-92
7	3/8"-16 Square Nut	JJ-11-JJ-3
8	Gear Shaft for Intermediate Gears	38-0045-267
9	Horizontal Stop Pin Assembly	38-0045-305
10	Stop Pin Cover	38-0045-329-M
11	Cam Assembly	38-0045-536
12	Staple	1265-4
13	Ventilator Screen	1265-6-B
14	Hasp Assembly	1265-40-1
15	Main Shaft Bearing	3580-166
16	End Cap	3580-291
17	Neoprene Gasket	3580-281
18	Gear Segment	3590-219-F
19	Gear Cluster	3590-220-F
19-A	Gear Cluster With Hole	3590-220-H
20	Main Shaft	3590-222
20-A	Single End (Right) Main Shaft (Not Shown)	3590-226
21	Nut, Nylon Insert, for Vertical Stop Assembly	3590-231
22	Main Shaft Cap	3590-232
22-A	Main Shaft Cap Without Hole (Not Shown)	3590-232-1
23	Case	3590-234-2-M
24	Cover	3590-240-2-M
25	Bearing	3590-249

**3597 CROSSING GATE MECHANISM  
REPLACEMENT PARTS (CONTINUED)**

**Refer to Figure 17**

<b>Ref. No.</b>	<b>Description</b>	<b>Part No.</b>
26	Set Screw	3590-251
27	Woodruff Key	3590-254
28	Cover Gasket	3590-258-2
29	3/8" Lockwasher	RR-00-AM-3
30	Spacer	3590-277
31	Spacer	3590-278
32	Spacer	3590-279
33	Vertical Stop Pin Assembly	3590-293
34	#8-32 x 3/8" Button Head Socket Cap Screw	BB-32-BB-3-0037
35	#10-24 x 1-1/4 Round Head Machine Screw	AA-10-CC-3-0125
36	#10 Split Lock Washer	RR-00-AH-3
37	3/8" Hex Nylok Nut	AL-12-JJ-3
38	1/4"-20 x 3/4" Hex Head Socket Cap Screw	BB-23-EE-3-0075
39	1/4"-20 x 3/4" Hex Head Socket Cap Screw	BB-23-EE-3-0075
40	Eyebolt	3590-381
41	3/8"-16 x 3/4" Socket Cap Screw	BB-59-JJ-3-0075
42	5/16"-18 x 2 1/4" Hex Head Bolt	CC-12-GG-3-0225
43	3/8"-16 Hex Nut	KK-12-JJ-3
44	1-1/4"-7 Hex Nut	JJ-12-AD-3
45	1-1/4" ID Flat Washer	3570-114
46	10-24 x 2-3/4" Round Head Machine Screw	AA-10-CC-3-0275
47	1/4" Plain Washer	PP-00-AJ-3
48	1/4"-20 x 3/8" Hex Socket Cap Screw	BB-23-EE-3-0037
49	5/16"-18 Hex Nylok	AL-12-GG-3
50	Installation Manual	3597-IM
51	Pinion Gear	3597-22
52	Mounting Kit for 5" Mast (Not Shown)	3590-294
53	Cap Screw	38-0045-282
54	Spacer for Bearing Cap	3590-275
55	Latch Holder Spring Kit	1265-40-SK



**3597-20 MOTOR ASSEMBLY  
REPLACEMENT PARTS  
REFERENCE A  
Figure 18**

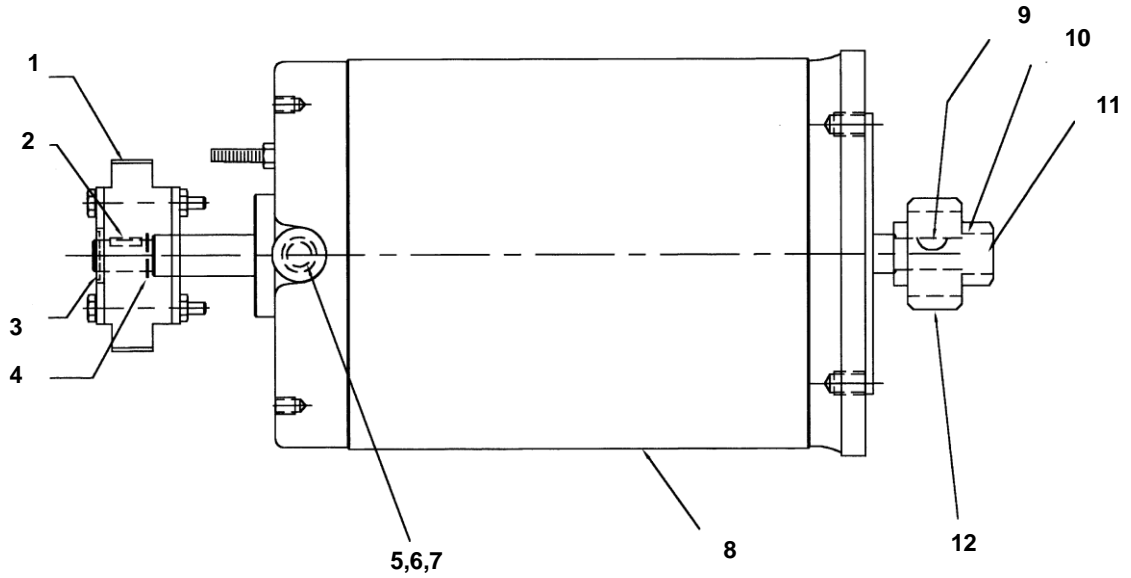

Ref. No	Description	Part No.
	Motor Assembly Complete	3597-20
1	Ratchet Wheel	38-0045-262
2	Ratchet Wheel Key	3580-270
3	Snap Ring	3580-271
4	Washer	38-0045-182
5	Motor Brush Cap	3597-20-12
6	Motor Brush	3597-20-13
7	Motor Brush Holder	3597-20-14
8	Motor	3597-20-1
9	Motor Pinion Woodruff Key	3597-21
10	Washer	38-0045-241
11	8-32 x 1/2" Nylock Round Head Machine Screw	BJ-10-BB-3-005
12	Motor Pinion Gear	3597-22

**38-0045-510 HOLD CLEAR ASSEMBLY  
REPLACEMENT PARTS  
REFERENCE B  
Figure 19**

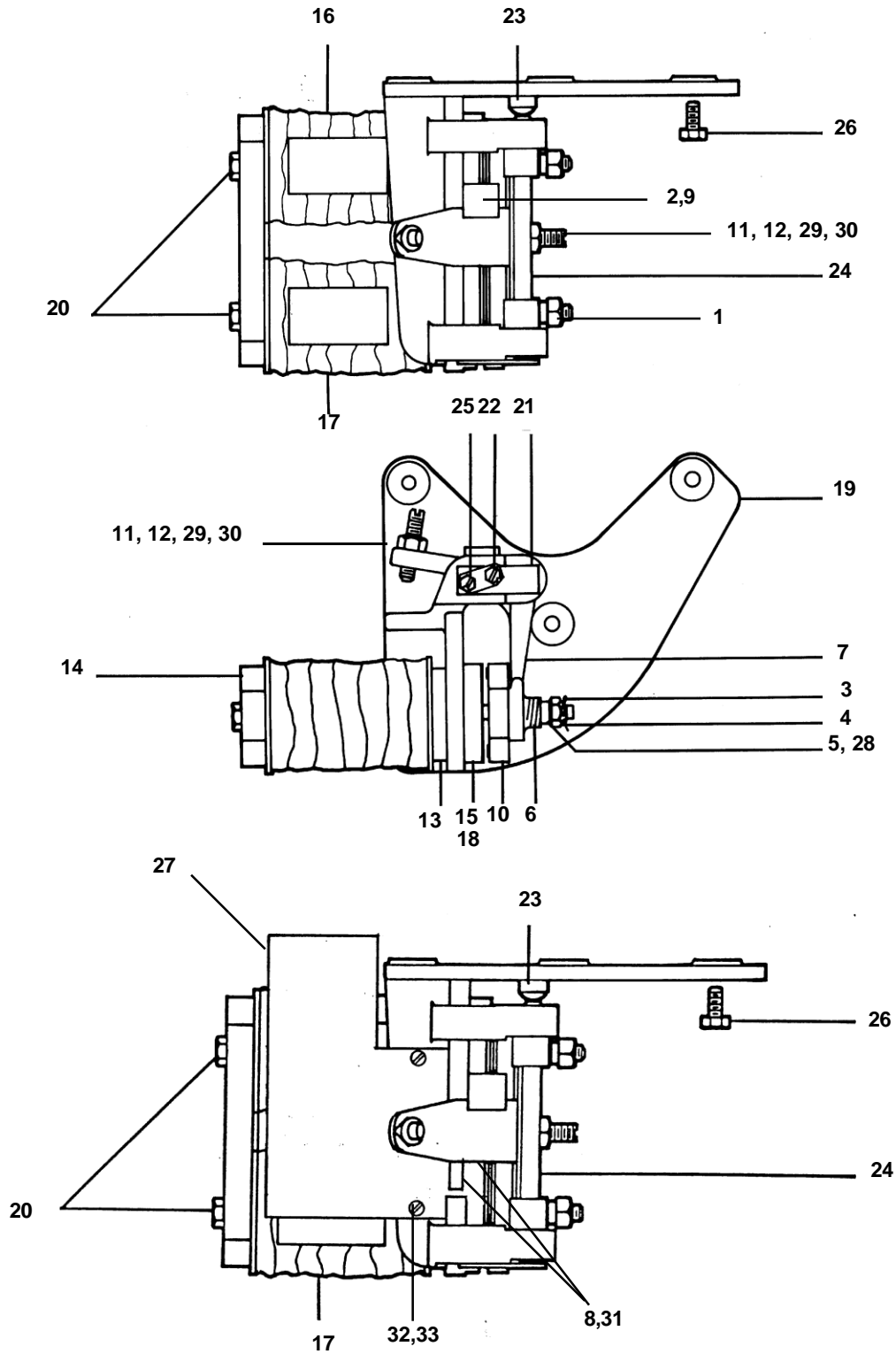

**38-0045-510 HOLD CLEAR ASSEMBLY  
REPLACEMENT PARTS  
REFERENCE B  
Refer to Figure 19**

<b>Ref. No.</b>	<b>Description</b>	<b>Part No.</b>
	Hold-Clear Assembly with Motor Down Contact Complete	38-0045-510
1	Armature & Support Bracket Assembly for Hold Clear With Motor Down Contact, Consists of Ref: 2,3,4,5,6,7,8,9,10,11,12,28,29,30 and 31	38-0045-159-1
2	Pawl	38-0045-7
3	Cotter Pin	38-0045-139
4	Castle Nut	38-0045-140
5	Cup Washer	38-0045-220
6	Compression Spring	38-0045-223
7	Armature Support Bracket	38-0045-319
8	Cam	38-0045-385
9	Pawl Mounting Screw	38-0045-261
10	Armature Sub-Assembly	38-0045-265
11	1/4-20 Hex Jam Nut	KK-12-EE-8
12	Set Screw	38-0045-266
13	Coil Spacer	38-0045-147
14	Magnet Yoke	38-0045-148
15	Magnet Pole and Core Sub-Assembly	38-0045-151
16	Hold Coil, 340 Ohms	38-0045-158
17	Pick Coil, 32 Ohms	38-0045-162
18	Mounting Screw, Pole/Core Sub Assy to Hold -Clear Base	38-0045-260
19	Hold-Clear Base For Contact Plate	38-0045-322
20	Mounting Screw, Magnet Yoke to Pole/Core Sub-Assembly	38-0045-264
21	Hinge Pin Stop	38-0045-152
22	Bolt/Screw Keeper	38-0045-153
23	Set Screw, Nickel Plated Brass	38-0045-157
24	Hinge Pin	38-0045-160
25	Hex Bolt, Nickel Plated Brass	38-0045-279
26	Hex Head Cap Screw, Grade 8	38-0045-282
27	Motor Down Contact Block	38-0045-513
28	Plain Washer 1/4 ID-7/16 OD x 1/32	AH-00-AJ-8
29	Nylok Nut 1/4 x 20	AL-00-EE-3
30	External Lock Washer	TT-00-AJ-3
31	#8-32x3/4 Filister Head Screw	AA-16-BB-3-0075
32	#8-32x1/4 Round Head Machine Screw	AA-10-BB-8-005
33	#8 Lockwasher	SS-00-AG-3

## 38-0045-513 MOTOR DOWN CONTACT BLOCK REPLACEMENT PARTS

Figure 20

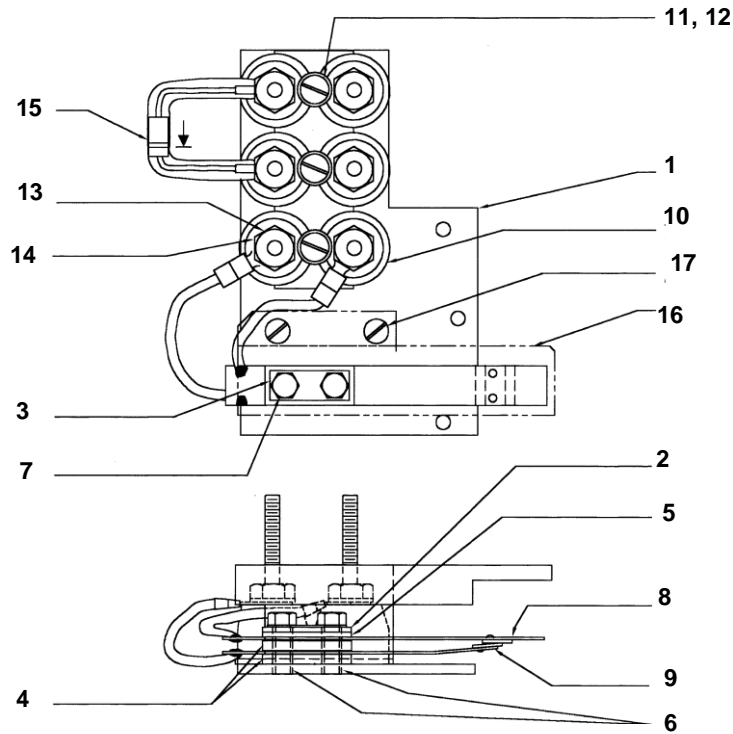

Ref. No	Description	Part No.
1	Contact Plate	38-0045-511
2	Washer Plate	38-0045-376
3	Keeper	38-0045-380
4	Mounting Block Spacer	38-0045-381
5	Spacer	38-0045-382
6	Insulator	38-0045-383
7	Screw	38-0045-384
8	Upper Contact Spring Assembly	38-0045-387
9	Lower Contact Spring Assembly	38-0045-388
10	Terminal Block	2507-6
11	#10-32 x 1/2 Round Head Machine Screw	AA-10-DD-8-005
12	#10 Lockwasher External	TT-00-AH-3
13	A.A.R. Clamp Nut	10707
14	Washer	10708
15	Diode Assembly	38-0045-512
16	Guard	38-0045-386
17	#8-32 x 1/4 Round Head Machine Screw	AA-10-BB-8-0025

# 38-0045-501 CIRCUIT CONTROLLER ASSEMBLY REPLACEMENT PARTS REFERENCE C

Figure 21

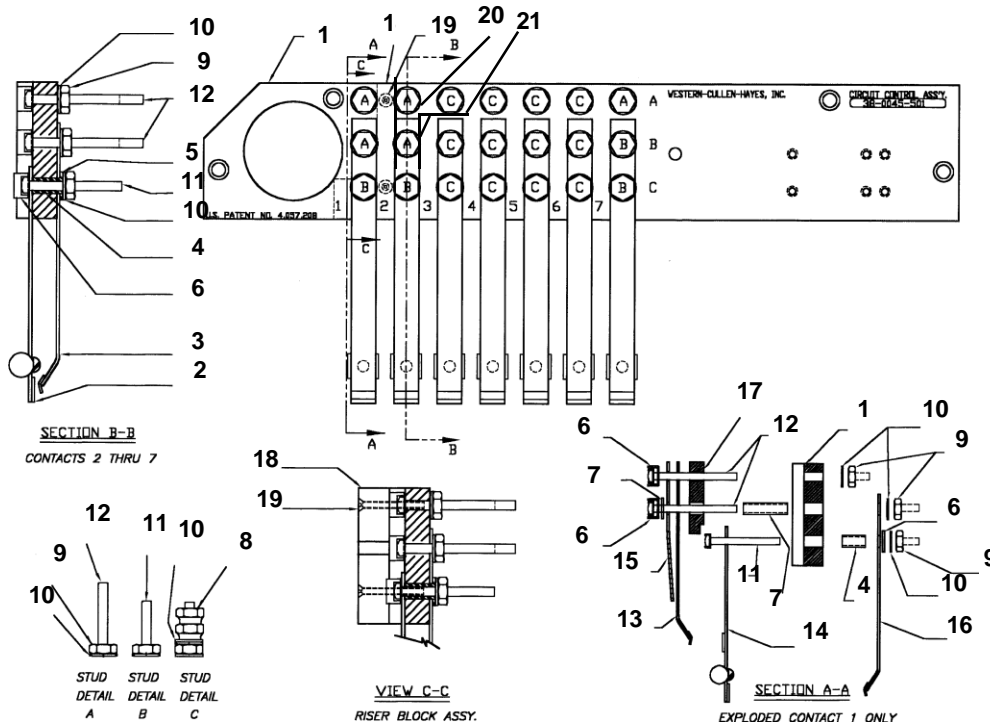

Ref. No	Description	Part No.
1	Terminal Board	38-0045-501-1
2	Back Contact. Contacts 2 thru 7	38-0045-27
3	Front Contact. Contact 2 thru 7	38-0045-28
4	Insulating Sleeve	38-0045-29-A
5	Insulating Washer	38-0045-29-B
6	Binding Post Seat	38-0045-77
7	Insulating Sleeve	38-0045-525
8	Binding Nut	10706
9	Clamp Nut	10707
10	AAR Washer	10708
11	Binding Post, 1-7/8" lg	10709-2
12	Binding Post, 2-1/4" lg	10709-3
13	Back Contact. Contact 1	38-0045-520
14	Heel Contact. Contact 1	38-0045-521
15	Contact Stiffener. Contact 1	38-0045-522
16	Front Contact. Contact 1	38-0045-523
17	Insulating Block	38-0045-505
18	Riser Block	38-0045-526
19	6-32x1-1/4" Flat Head Screw	38-0045-527
20*	Test Link	38-0045-89-R
21*	Test Nut	38-0045-290

\* = Units with PC Relay Board

**3597-3 CONTROL ASSEMBLY  
REPLACEMENT PARTS  
REFERENCE D**

**Figure 22**

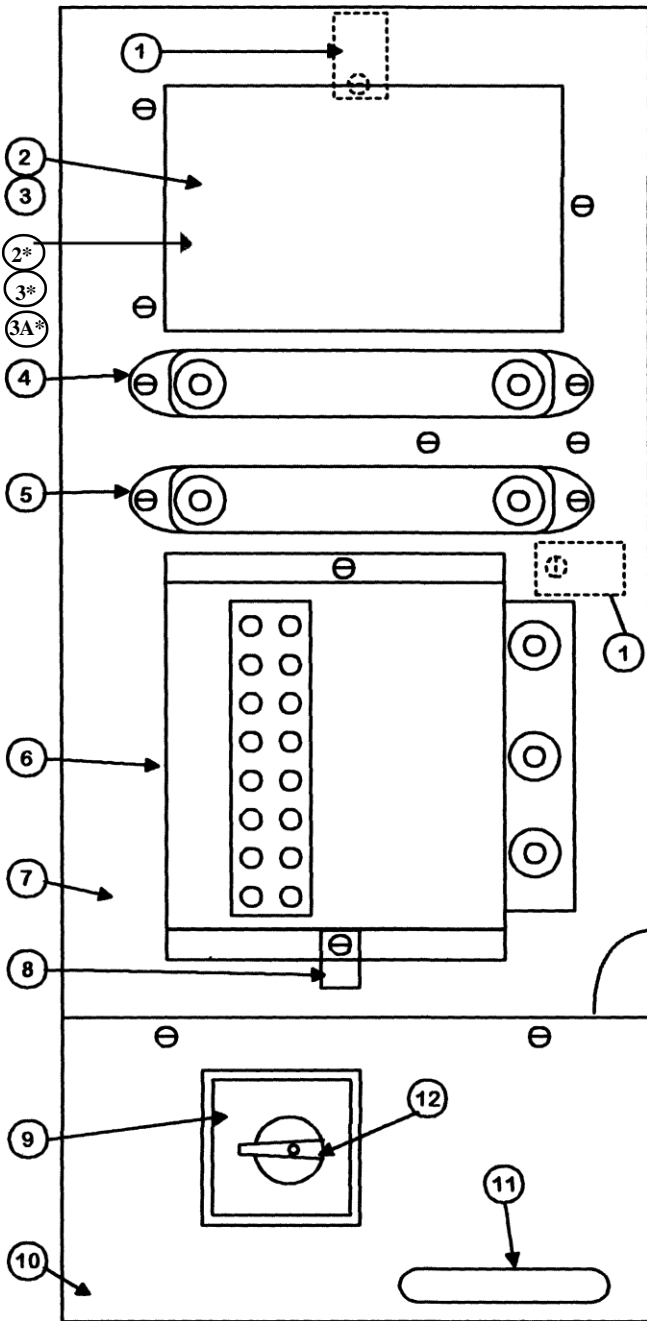

Ref. No.	Description	Part Number
1	Wire Clamp	1953-12-B
2	Relay, P&B, Type PM	91254-12
2*	Relay Board	3597-10-3
3	Relay Cover	91254-1
3*	Base	3597-10-2
3A*	Relay, P&B, Type VF4	3597-10-1
	Items 2,3,3A* Complete	3597-10
4,5	1.5 Ohm Resistor	1110-2
6	Electronic Gate Monitor	3597-1
7	Relay Panel	3597-3-1
8	Wire Clamp	1953-6-A
9	Cam Switch Complete	3597-2
10	Cam Switch Panel	3597-3-2
11	Lube Label	38-0045-500
12	Cam Switch Knob	3597-2-1

\* = Units with PC Relay Board  
Replacement Parts Only

**3597 CROSSING GATE MECHANISM  
SIDEWALK GATE ARM KIT  
REFERENCE E**

**Figure 23**

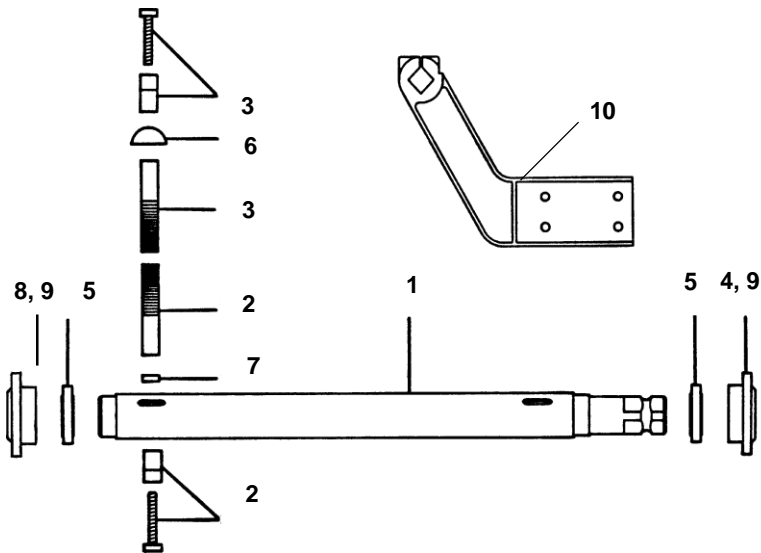

<b>Ref. No.</b>	<b>Description</b>	<b>Part No.</b>
	Sidewalk Arm Shaft Kit (for Right or Left Hand use)	3590-295
1	Sidewalk Arm Shaft	3590-223
2	Gear Segment w/Clamp and Assembly Bolts, for Sidewalk Shaft.	3590-224
3	Gear Segment w/clamp and Assembly Bolts, for Main Shaft.	3590-225
4	Collar	3590-227
5	Bearing	3590-248
6	Woodruff Key, for Main Shaft	3590-254
7	Key, for Sidewalk Shaft	3590-255
8	Cap	3580-226-M
9	1/4-20 x 3/4 Machine Socket Screw	AA-15-EE-3-0075
10	Sidewalk Arm Adaptor (not included in kit)	3565-111

**3597 CROSSING GATE MECHANISM  
CONTACT HEATER ASSEMBLY  
REFERENCE F**

**Figure 24**

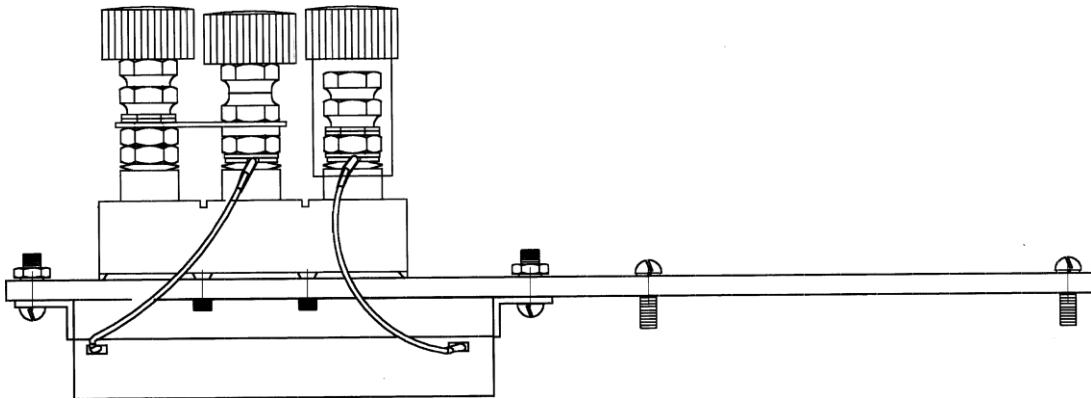

Ref. No.	Description	Part No.
F	Contact Heater Assembly Complete, 115 VAC, 50 Watt, 500 Ohms	3597-4
F1	Contact Heater Assembly Complete, 24 VDC, 50 Watt, 25 Ohms	3597-5
F2	Contact Heater Assembly, 12 VDC, 50 Watt, 10 Ohms	3597-6



**38-0045-540 GATE LAMP FUSE PANEL  
REPLACEMENT PARTS  
REFERENCE G  
Figure 25**

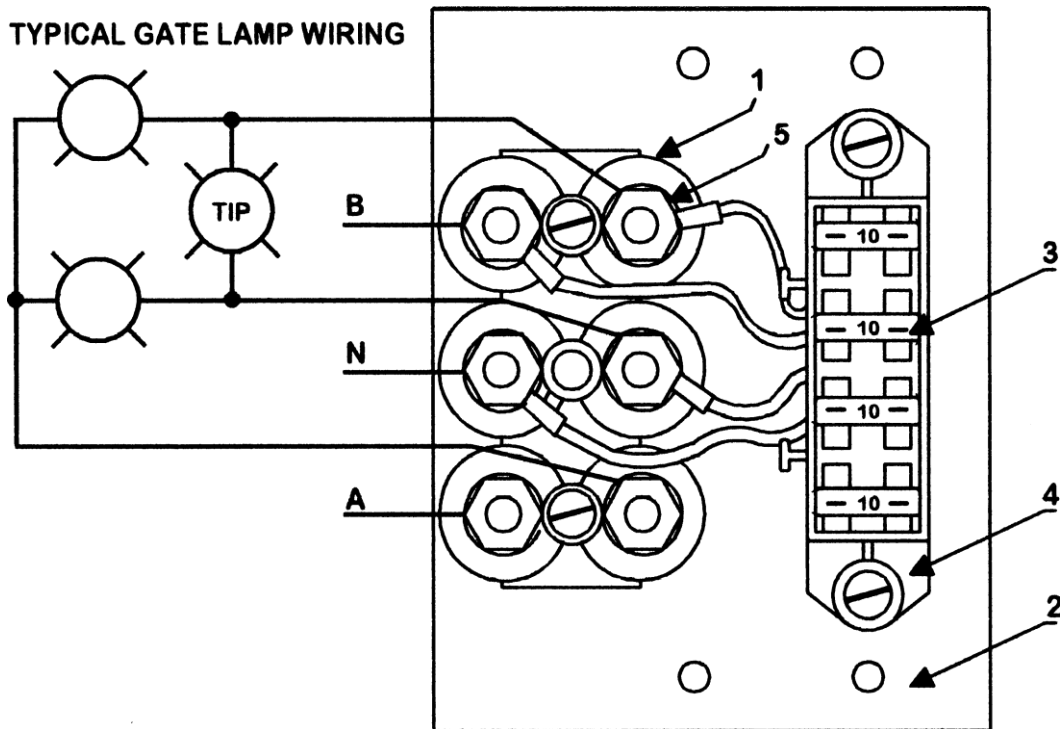

Ref. No	Description	Part No.
1	Terminal Block	2507-6-1
2	Panel	38-0045-541
3	10 AMP Type ATC Fuse	400-35-50
4	Fuse Holder	50-0274
5	Crimp Terminal	31908-MT

## Set-Up and Adjustment Tools

### Spring Scale, PN: 3562-210

Used for measuring gate arm torque.

### Torque wrench with socket, PN: 3590-K-9.

Used for measuring gate arm torque.

### Snap ring pliers, PN: 3590-1007

Used for ratchet wheel removal.

### .020 gauge, PN: 3590-1012

Used to adjust ratchet wheel to hold clear pawl clearance.

### .032 gauge, PN: 3590-1011

Used to adjust gap on hold clear mounted power down contact.

### Ounce spring scale, PN: 3565-211

Used to measure contact spring pressure.

### 1/16" insulated gauge, PN: 3590-1010

### 1/8" insulated gauge, PN: 3590-1015

Used to check contact gap.

### Contact bending tool for contacts without stiffeners, PN: ES-6104-2

### Contact bending tool for contacts with stiffeners, PN: ES-6104-1

Used to adjust circuit board contact.

### Angle finder, PN: 3590-1014

Used to set contact cam operating position.

### 3/32" wire gauge, PN: 3590-1013

Used to check vertical stop to segment gear clearance.

### Tool kit, PN: 3590-K-11

Includes snap ring pliers, 3/32", 3/16" and 7/32" T handle allen wrenches, 7/16" combination wrench and canvas pouch.

### Aeroshell 33 lubricating grease, PN: 3590-1733

For lubrication of gears, 1 quart can.

## **THE TWO-WAY GATE-GARD**

### **Part Number: D-1074**

The TWO-WAY GATE-GARD is a device installed between a railroad grade crossing gate arm and the arm and the operating mechanism which allows the gate arm to rotate about an axis perpendicular to the gate arm length.

The purpose of the device is to minimize gate arm damage from wind pressure, vandalism or from contact with vehicles. The Gate Gard provides flexibility to the gate arm joint and allowing the lowered gate arm to rotate in a direction parallel with the roadway upon contact with, or pressure to, either side of the gate arm.

The TWO-WAY GATE-GARD can be installed on new or in service Western-Cullen-Hayes type grade crossing systems without making alterations to the existing gate arm or its operating mechanism. Some counterweight adjustment may be necessary.

#### **TWO-WAY GATE-GARD SPECIFICATIONS**

Attaches to the counterweight support arms of any standard crossing gate mechanism, replacing the existing gate arm adapter and conversion bracket.

Incorporates a spring loaded mechanical latch system to lock the gate arm firmly in its conventional position under normal operating conditions and allows the Latch Hook to release when the gate arm rotating forces are applied.

Features a return spring system capable of bringing the longest gate arm back to their normal, locked position when the rotating force is relieved.

Has a drag brake, with a replaceable bronze wear plate, built into the latch hook system to retard the speed of the returning gate arm.

Includes brass pins with locknuts to provide additional resistance to gate arm rotation in high wind areas.

#### **MAINTENANCE**

The TWO-WAY GATE-GARD requires no lubrication or adjustments, It should, however, be inspected on a regular basis to ensure that there are no loose fasteners or broken parts due to impact damage and to determine that the gate arm rotates and returns properly.

#### **WEAR PLATE**

Check the bronze Wear Plate (19) for excessive wear if the unit is in a high usage location. The Wear Plates can be replaced, if necessary, without removing the gate arm from Gate Arm Adapter (2) or removing the TWO-WAY GATE-GARD from the crossing gate mechanism. Rotate arm slightly for access to the front mounting screws.

#### **RETURN SPRINGS**

Springs (16) can be replaced, if necessary, without removing the gate arm from the Gate Arm Adapter (2) or removing the TWO-WAY GATE-GARD from the crossing gate mechanism.

Remove the lock screws and nuts at the end of the Return Spring Housing (11) and back off the Slotted Nuts (40) to relieve the spring pre-load.

Remove the lock screw and nut from the Spring Pin Spacer (10) and remove the Return Spring Housing Pin (9). Rotate the Spring Housing (11) away from the counterweight support arms for spring removal clearance.

## TWO-WAY GATE-GARD INSTALLATION INSTRUCTIONS

### Part Number: D-1074

1. Lower the gate mechanism and crossing gate arm to the horizontal position and lock the mechanism in place and/or block up the counterweight to prevent moving of the counterweight support arms.
2. Remove the gate arm from the existing gate arm adapter and remove the existing adapter and conversion bracket from the counterweight support arms.
3. Slide the Two-Way Gate-Gard over the counterweight support arms. Apply a small amount of anti-seize compound to the threads of the mounting bolts (31) and secure but do not tighten. Remove the wood spacer blocks between the channels, tapping the lower channel to loosen if necessary.
4. Tighten the bolts securing the channels to the counterweight support arms.
5. Re-install the existing gate arm to the Gate Arm Adapter (2).
6. Check the horizontal and vertical torque of the crossing gate mechanism per specifications and re-adjust the counterweight positions if necessary.
7. Grasp the gate arm near the mid length point, rotate the arm 30 degrees or so and release. Repeat 3 or 4 times to allow the Latch Hook (15) to disengage from the Gate Arm Adapter (2) and to break-in the leading edge of bronze Wear Plate (19) Clean off any metallic particles that may accumulate during break-in. Repeat this process for the opposite direction of rotation.
8. Check for zero clearance between the end of the Latch Spring Rod (14) and the Latch Hook (15). Adjust hex nut (38) and jam nut (39) at the bottom of Rod (18) if necessary, while maintaining the alignment of the gate arm and the mast.
9. Shear Pins (21) with lock nuts (27) can be installed through the Cross Channels (1) and the Gate Arm Adapter (2) to provide additional resistance to rotation in high wind areas if necessary.

The Gate -Gard return spring systems designed to provide rotation resistance in high wind conditions and to provide adequate power to return a rotated gate arm of up to forty feet in length, to its normal position.

In some circumstances, when short gate arms are used, it may be desirable to reduce the return spring energy. This will slow the return speed of a rotated gate arm as well as reduced the impact energy necessary to rotate the gate arm.

The Gate-Gard's spring force can be reduced in any of three ways:

1. Reduce the number of washers, (41) at the end of each return spring housing tubes (11) from five to one. The Gate-Gard does not have to be removed from the crossing gate mechanism to do this modification. Simply remove the locking hardware (23), (25), (26) and back off the slotted nut (40). Remove all but one washer (41) and re install nut (40) and locking hardware. This procedure will reduce the gate arm's resistance to rotation from its normal position but will have minimal effect on the gate arm's return speed.
2. Remove the middle return spring (16) from the Gate-Gard. Again, the Gate-Gard does not have to be taken off the gate mechanism to do this modification. Remove the nuts (40) and washers (41) from the six return springs assemblies as outlined in Step 1. Remove the locking hardware (24), (25) and remove the return spring housing pin (9), spring pin spacer (10) and thrust washer (5). Next, swing the spring housing (11) away from the Gate-Gard and slide out the center spring (16). Thread a 3/4 - 10-jam nut, one washer (41) and slotted nut (40) onto the end of this center connecting rod (12) to keep it centered in the tube. Reposition the spring housing (11) and reinstall the housing pin (9) with spacer (10), washer (5) and locking hardware. Reinstall the five washers on each of the other four connecting rods (12) with nuts (40) and locking hardware.

Note that the washers must be below the end of each spring tube.

This step will reduce the gate arm's resistance to rotation from the normal position and will reduce the return speed from a rotated gate arm.

3. Steps one and two can be used together to achieve the exact combination of resistance to rotation and gate arm return speed desired for a particular application.

Please contact Western-Cullen-Hayes with any questions you have regarding the modification of our Gate-Gard adapter.

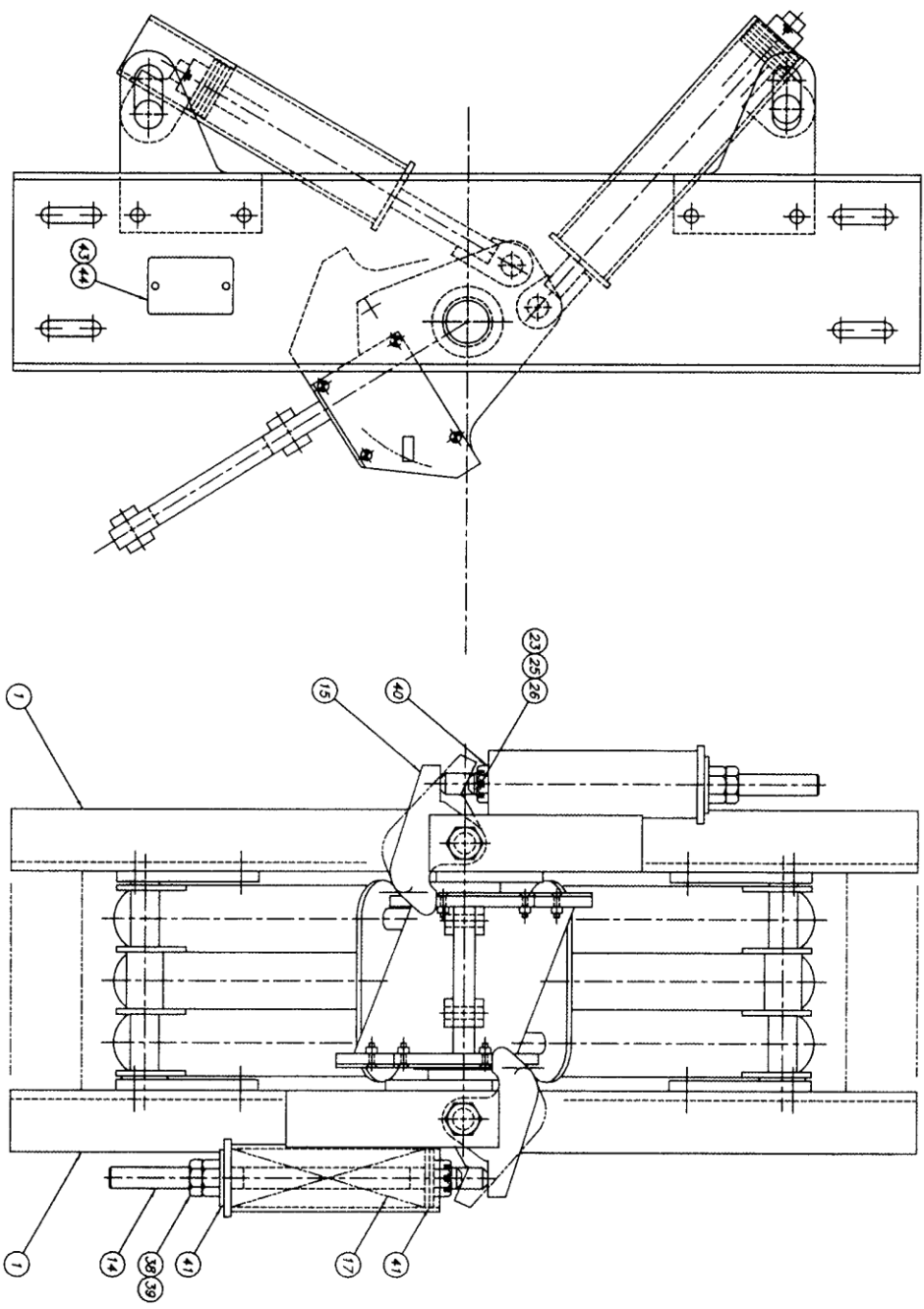

ESTIMATED ASSEMBLY WEIGHT = 142 LBS.

1	2	C-1034-2	CROSS CHANNEL
2	1	C-1037-1	DATE ARM ADAPTER
3	1	A-1289	FINICE PIN BRUSHING
4	1	B1-1029	THRUST WASHER
5	2	A-1290	THRUST WASHER
6	1	A-1289-1	FINICE PIN
7	2	A-1289-1	SPRING ROD CONNECTING PIN
8	4	A-1300-1	SPRING ROD SPACER
9	2	A-1301-1	RETURN SPRING HOUSING PIN
10	2	A-1302-1	SPRING PIN SPACER
11	2	B-1089-2	RETURN SPRING HOUSING
12	6	A-1308-2	SPRING CONNECTING ROD
13	4	A-1309-1	SPRING ANCHOR BRACKET
14	2	A-1313-1	LATCH SPRING ROD
15	2	B-1071-1	LATCH HOOK
16	6	A-1148-8	RETURN SPRING
17	2	A-1148-3	LATCH SPRING
18	2	A-1315	LATCH HOOK PIVOT PIN
19	2	B-1074	WEAR PLATE
20	1	A-1288-1	LOWER RANGE BRACKET
21	2	B-1027-13-1	BALLS SHEAR PIN
22	6	A4-14-02-8-0087	#10-32 x 7/8 BR FL HD SCR
23	12	A4-10-02-3-019	#10-32 x 1 1/2 RND HD SCR
24	2	A4-10-02-3-0178	#10-32 x 1 3/4 RND HD SCR
25	22	A4-12-02-3	#10-32 NY-LOCK NUT
26	20	PP-00-4W-3	#10 PLAIN WASHER
27	2	A4-12-02-3	5/16-18 NY-LOCK NUT
28	1	B8-12-4L-3-046	3/8-18 x 4 1/2 HEX BOLT
29	1	A4-12-4L-3	3/8-18 NY-LOCK NUT
30	10	PP-00-4W-3	7/16 PLAIN WASHER
31	6	CC-11-PP-3-0178	1/2-13 x 1 3/4 SQ HD BOLT
32	6	CC-12-PP-3-0178	1/2-13 x 1 3/4 HEX SCR
33	2	CC-12-PP-3-02	1/2-13 x 2 HEX SCR
34	10	A4-12-PP-3	1/2-13 NY-LOCK NUT
35	6	HH-12-PP-3	1/2-13 HEX NUT
36	6	PP-00-4W-3	1/2 PLAIN WASHER
37	6	RR-00-4W-3	1/2 LOCKWASHER
38	2	LL-12-4L-3	3/4-10 HEX NUT
39	2	RR-12-4L-3	3/4-10 HEX NUT
40	10	MM-12-4L-3	3/4-10 SLOTTED HEX NUT
41	36	A-1435	1 5/16 OD WASHER
42	1	VW-00-8W-3-025	3/16 x 2 1/2 COTTER PIN
43	1	A-1430	HADEPLATE
44	2	AS-10-A-3-0225	#6 x 1/4 DRIVE SCREW
45	1	A-1431	CABLE TIE

NOTE:  
 SHEAR PIN (21), LOCKWASHER (37), PLAIN WASHER (36), (38), (39), (40), (41), (42), (43), (44), (45) INSTRUCTION MANUAL AND PARTS LIST IN PLACER. BKG ATTACHED TO THE UNIT WITH CABLE TIE A-1431.

WESTERN-COLEMAN-HAWES, INC.	
DATE: 5/2/74	BY: [Signature]
REV: 1	DATE: 5/2/74
REV: 2	DATE: 5/2/74
REV: 3	DATE: 5/2/74
REV: 4	DATE: 5/2/74
REV: 5	DATE: 5/2/74
REV: 6	DATE: 5/2/74
REV: 7	DATE: 5/2/74
REV: 8	DATE: 5/2/74
REV: 9	DATE: 5/2/74
REV: 10	DATE: 5/2/74
REV: 11	DATE: 5/2/74
REV: 12	DATE: 5/2/74
REV: 13	DATE: 5/2/74
REV: 14	DATE: 5/2/74
REV: 15	DATE: 5/2/74
REV: 16	DATE: 5/2/74
REV: 17	DATE: 5/2/74
REV: 18	DATE: 5/2/74
REV: 19	DATE: 5/2/74
REV: 20	DATE: 5/2/74
REV: 21	DATE: 5/2/74
REV: 22	DATE: 5/2/74
REV: 23	DATE: 5/2/74
REV: 24	DATE: 5/2/74
REV: 25	DATE: 5/2/74
REV: 26	DATE: 5/2/74
REV: 27	DATE: 5/2/74
REV: 28	DATE: 5/2/74
REV: 29	DATE: 5/2/74
REV: 30	DATE: 5/2/74
REV: 31	DATE: 5/2/74
REV: 32	DATE: 5/2/74
REV: 33	DATE: 5/2/74
REV: 34	DATE: 5/2/74
REV: 35	DATE: 5/2/74
REV: 36	DATE: 5/2/74
REV: 37	DATE: 5/2/74
REV: 38	DATE: 5/2/74
REV: 39	DATE: 5/2/74
REV: 40	DATE: 5/2/74
REV: 41	DATE: 5/2/74
REV: 42	DATE: 5/2/74
REV: 43	DATE: 5/2/74
REV: 44	DATE: 5/2/74
REV: 45	DATE: 5/2/74

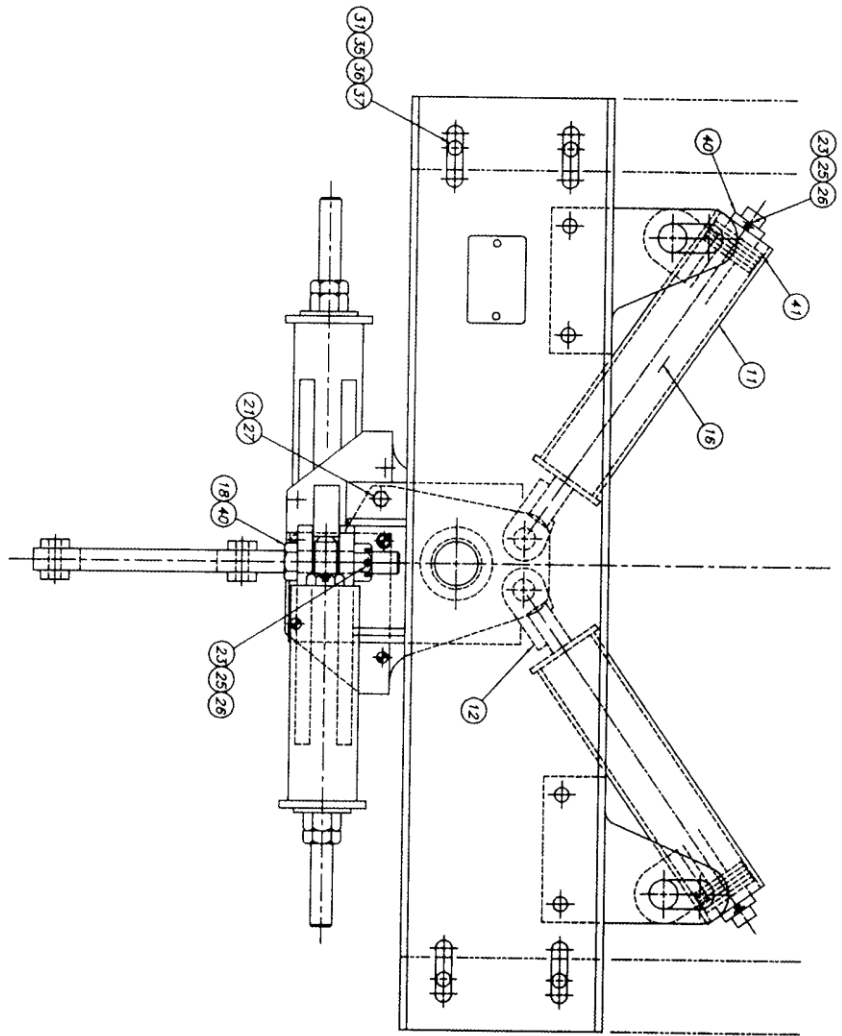
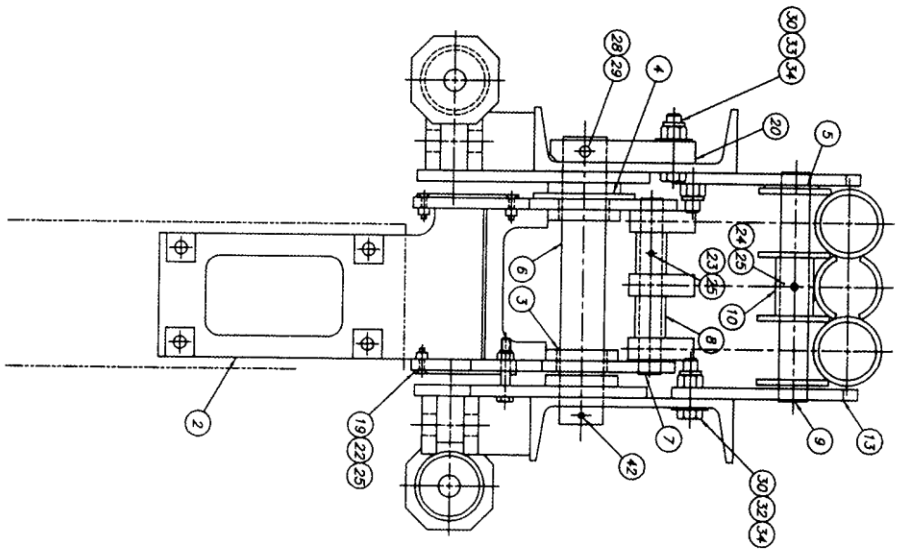

WESTERN GILLEN-HAYES, Inc.		THE MILITARY GUNZ-GARD ASSEMBLY	
Part No.	D-1074	Rev.	1/2
Scale	1/2"	Material	Steel
Quantity	1	Weight	1.0000
Drawn by		Checked by	
Approved by		Released by	
1. ALL DIMENSIONS UNLESS OTHERWISE SPECIFIED ARE IN INCHES. 2. ALL DIMENSIONS UNLESS OTHERWISE SPECIFIED ARE TO BE HOLD TO TOLERANCES SHOWN. 3. ALL DIMENSIONS UNLESS OTHERWISE SPECIFIED ARE TO BE HOLD TO TOLERANCES SHOWN. 4. ALL DIMENSIONS UNLESS OTHERWISE SPECIFIED ARE TO BE HOLD TO TOLERANCES SHOWN. 5. ALL DIMENSIONS UNLESS OTHERWISE SPECIFIED ARE TO BE HOLD TO TOLERANCES SHOWN.			

### INSTALLATION INSTRUCTIONS

1. LOWER THE GATE MECHANISM TO THE GATE ARM HORIZONTAL POSITION AND LOCK THE MECHANISM IN PLACE AND/OR BLOCK UP THE COUNTERWEIGHT SUPPORT ARMS.
2. SLIDE THE SWING AWAY ARM JOINT ASSEMBLY OVER THE EXISTING GATE ARM ADAPTER.
3. INSTALL TWO HEX SCREWS (7) WITH WASHERS (9) AND LOCK NUTS (10) DO NOT TIGHTEN.
4. WITH SWING AWAY ADAPTER (2) AGAINST THE EXISTING GATE ARM ADAPTER SLIDE HEX SCREWS (8) INTO PLACE.
5. ADJUST LEVELING SCREW (11) SO THAT HEX SCREWS (8) SLIDE FREELY THROUGH HINGE BRACKET (1) SWING AWAY ADAPTER (2) AND THE EXISTING GATE ARM ADAPTER.
6. TIGHTEN HEX SCREWS (7).
7. RE-CHECK THAT HEX SCREWS (8) SLIDE FREELY AND TIGHTEN JAM NUT (12) LOCKING LEVELING SCREW (11) IN PLACE.
8. REMOVE HEX SCREWS (8) AND ROTATE SWING AWAY ADAPTER (2) 90 DEGREES TO THE PARALLEL WITH ROADWAY POSITION.
9. INSTALL THE GATE ARM TO THE SWING AWAY ADAPTER (2) IN THE NORMAL MANNER.
10. ROTATE THE GATE ARM AND THE SWING AWAY ADAPTER (2) TO THE ORIGINAL POSITION AND INSTALL TWO HEX SCREWS (8) WITH WASHERS (9) AND LOCK NUTS (10).
11. RE-ADJUST LEVELING SCREW (11) IF NECESSARY TO ALLOW SCREWS (8) TO SLIDE FREELY AND TIGHTEN NUTS (10).

### NOTE:

ALWAYS LOCK THE MECHANISM IN THE GATE ARM HORIZONTAL POSITION BEFORE ROTATING THE GATE ARM AND THE SWING AWAY ADAPTER.

PARTS LIST		
ITEM	QTY	DESCRIPTION
1	1	HINGE BRACKET MACHINED
2	1	SWING AWAY ADAPTER MACHINED
3	2	ADAPTER SPACER
4	1	HINGE PIN
5	1	AA-10-DD-3-015 No 10-32 x 1 1/2 RND. HD. SCREW
6	2	BB-12-J1-3-0275 3/8-16 x 2 3/4 LG. HEX SCREW
7	2	BB-12-J1-3-0275 3/8-16 x 3 1/2 LG. HEX SCREW
8	2	PP-00-AK-3 3/8-16 NY-LOK NUT
9	2	AL-12-DJ-3 3/8-16 NY-LOK NUT
10	4	CC-12-PP-3-015 1/2-13 x 1 1/2 LG. HEX SCREW
11	1	KK-12-PP-3 1/2-13 HEX JAM NUT
12	1	5612-62 CAUTION NAMEPLATE
13	1	AS-10-AF-3-0025 No 6 x 1/4 DRIVE SCREW
14	2	

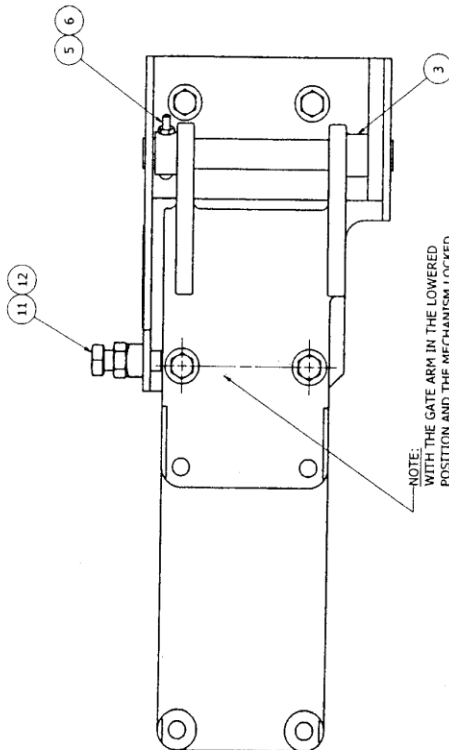
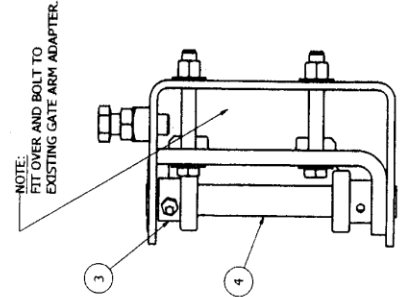
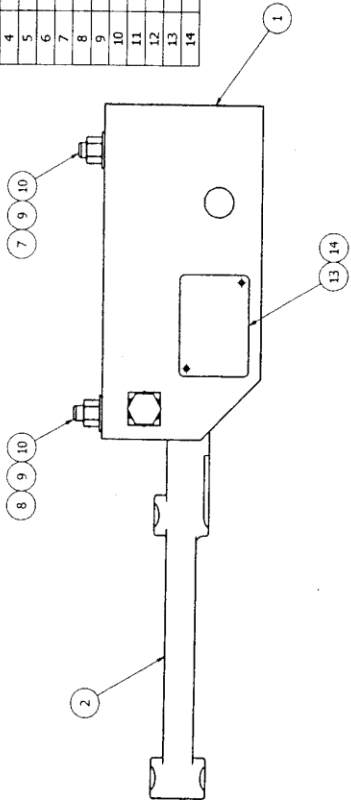

NOTE:  
WITH THE GATE ARM IN THE LOWERED POSITION AND THE MECHANISM LOCKED, REMOVE THESE TWO SCREWS TO SWING THE ARM AWAY FROM THE ROADWAY.

EST WEIGHT = 25 LBS

DRAWN		DATE		BY		TITLE		
R.P.	11-13-08	WESTERN CULLEN HAYES, INC.	2700 WEST 18th PLACE - CHICAGO, IL 60632-1682				SWING AWAY ARM JOINT	
CHECK							INSTALLATION	
APPROV								
SCALE	1/2							
SHEET	C							
OF								
1. UNLESS OTHERWISE SPECIFIED DIMENSIONS ARE IN INCHES TOLERANCE ON UNFINISHED DIMENSIONS								
DECIMALS .XX +.010 .XXX +.005								
FRACTIONS +1/164								
ANGLES +.12 DEG								
2. REMOVE ALL BARRIS								
REVISIONS		DATE		BY		USED ON		
A	9388-A	4-07-09	BW/C					
B	9388-B	1-29-09	BW/C					
C								
THIS PART IS THE PROPERTY OF WESTERN CULLEN HAYES, INC. AND SHALL REMAIN UNREMOVED, COVERED OR OBTAINED IN ANY MANNER UNLESS AUTHORIZED BY THE PATENT OFFICE.								
PART NUMBER C-1065-1C-INST								